



Contents

Introduction	1	Strong economy and thriving communities	27	Acknowledgement of country
About this report	1	Indirect social and economic impacts	27	Toyota Australia recognises the reach and influence of its operations throughout Country, and the Aboriginal and Torres Strait Islander peoples who are custodians of those lands. We acknowledge the Traditional Custodians of the land on which we meet today, and pay our respects to Elders past, present and emerging and any Aboriginal and Torres Strait Islander people who are here today. As part of Toyota Australia's commitment to diversity and inclusion, we recognise all cultures present today.
President and CEO statement	2	Supply chain risk	28	
What we do and how we create value	3	Dealer network	30	
Governance	10	Community investments and partnerships	31	
		Skillsets for the Australian community	33	
Reimagined mobility experience	13	Regional engagement	34	
Customer preference and satisfaction	13			
Shared services	14	Capable, accomplished people	35	
		Workforce engagement and communication	36	
Safer, better vehicles and technology	15	Workforce skills and development	37	
Product safety and quality	15	Diversity and inclusion	39	
Connected and automated vehicles	16	Employee health, safety and wellbeing	41	
Data privacy and security	18			
Strategic partnerships	19	Appendix	42	
Advocacy and regulatory engagement	19	Data tables	42	
		Our philosophy and values	45	
Reducing environmental impacts	20	Information on Directors	46	
Lower carbon mobility	20	GRI index	47	
Vehicle lifecycle	23	SASB index	48	
Operational environmental impacts	23			

Introduction

About this report

This report is Toyota Australia's 16th annual sustainability report. The information in this report covers the period 1 April 2021 to 31 March 2022 ('reporting period'), in alignment with the Japanese financial year.

This report presents the sustainability activities and performance of Toyota Australia and Lexus Australia, a division of Toyota Australia. Unless specifically mentioned, the report does not cover the activities of our affiliated dealerships or Toyota Financial Services Australia, which is a separate entity. Toyota Australia ownership remained unchanged during the reporting period.

We have drawn on the Integrated Reporting Framework (<IR>), the Global Reporting Initiative (GRI) Standards 2021 and the Sustainability Accounting Standards Board's (SASB) automobile industry standards to guide the preparation and content of this report, including the materiality assessment. The GRI and SASB indexes are on [p. 47](#) and [p. 48](#). Further information on our materiality process is on [p. 49](#).

This report is structured according to five thematic areas and addresses our approach to the material topics that are important to our stakeholders and our business. The information in this report has been reviewed by Toyota Australia's Board. We have engaged an independent external service provider to assure aspects of this report, as detailed in the statement on [p. 49](#).

There is one restatement of data from our 2021 sustainability report regarding solar generation. See data tables on [p. 42](#) for more information.

Toyota Australia's previous sustainability reports are available on the Toyota Australia website. For questions about our reports or sustainability at Toyota, contact sustainability@toyota.com.au.

What we do and how we create value

Toyota Motor Corporation Australia Limited ('Toyota Australia' or 'TMCA') is a wholly owned subsidiary of Toyota Motor Corporation (TMC). TMC is a publicly listed company and the largest vehicle manufacturer in Japan. Lexus Australia is managed as a separate division.

Our corporate headquarters are located in Port Melbourne, Victoria, and we have regional offices throughout Victoria, New South Wales, Queensland and South Australia. In Western Australia, Toyota Australia distributes Lexus-branded vehicles to dealers, and Toyota-branded vehicles are distributed by Toyota Western Australia (TWA), which operates as an independent company. In all other states and territories, Toyota Australia is responsible for both Lexus and Toyota vehicle distribution to dealers. The network of Toyota and Lexus franchised dealers extends across all Australian states and territories.

Toyota serves a diversified customer base consisting of rental, corporate, fleet and private customers. The Toyota vehicles sold in Australia are imported from our affiliates overseas and our customers are supported by our local network of experienced dealers, operating under independently owned franchise agreements.

Where we are located

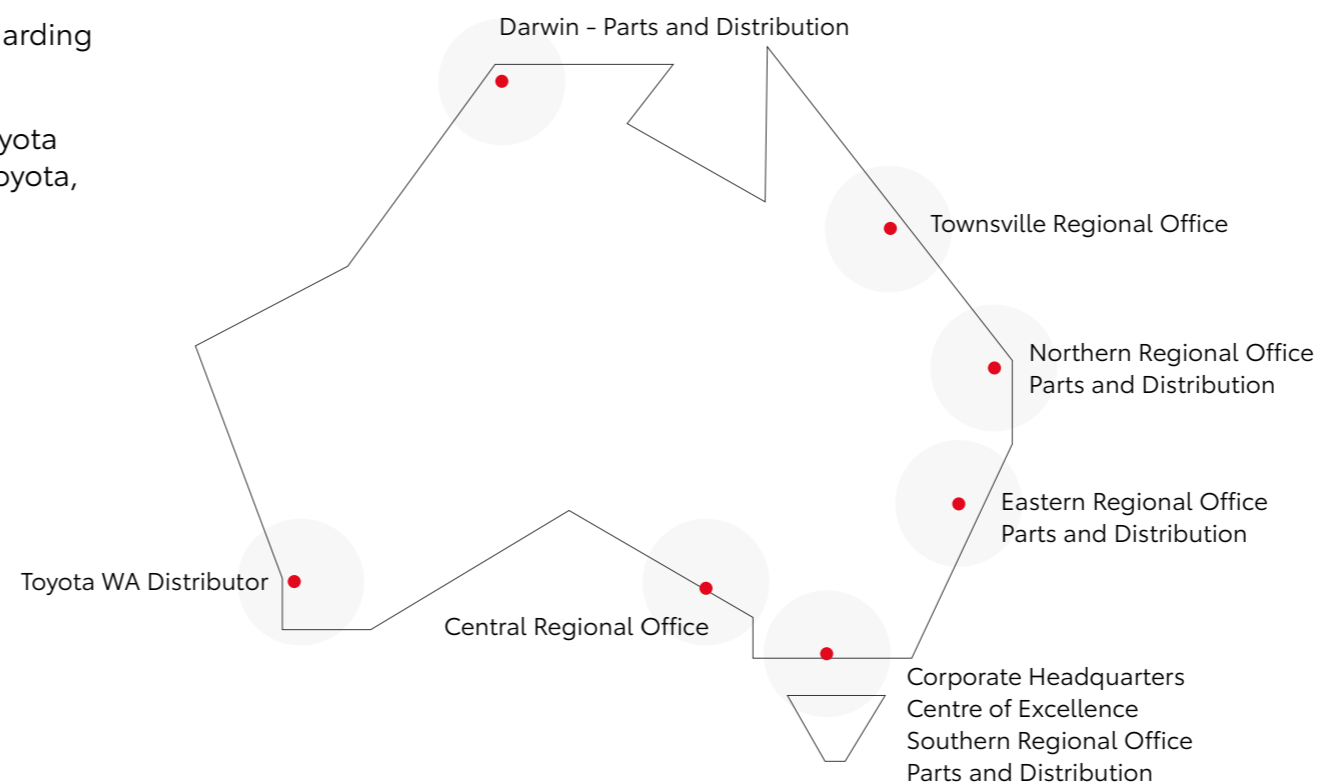

President's Message 2022



We are approaching an important turning point in the evolution of the Australian auto industry. At Toyota Australia, we are extremely excited about the growing momentum and opportunities that are developing in the mobility landscape.

Creating efficient mobility solutions for all Australians is our number one priority at Toyota Australia. This aligns with Akio Toyoda's global mission of 'producing happiness for all', making sure we contribute to our environment, society, and the changing needs and desires of consumers.

As Australia's number one selling automotive company, we are taking action towards building a sustainable society, adapting our strategies to ensure we play our role as a responsible corporate citizen.

In a post COVID world, we continue to face enormous challenges as a society, including growing supply challenges, labour shortages, the ongoing war in Ukraine, changes in regulations and of course, the rising costs of living.

At Toyota Australia, we understand the stress our customers continue to face, especially the disappointment that is felt due to the current supply chain disruption. We are in constant discussion with our parent company to improve this situation, working back with our affiliates, our dealer network, and partners to complete orders as quickly as possible.

Last year, we began our journey towards our 2030 Direction, with a vision of 'Connecting us all with the freedom to move and be moved'. A large part of this, has been to focus on developing plans that have a holistic approach, embedding sustainability in all our activities to contribute towards the United Nations Sustainable Development Goals.

It was back in 2015, when we established our global environmental commitment to ensure we do our part to create a more sustainable future for our people, business, and planet. As

climate change impacts our world, we understand the role vehicles play in contributing to global emissions and the need for action. Globally, Toyota is committed to achieving zero CO2 emissions from its vehicles and plants under the Toyota Environmental Challenge 2050, and here in Australia, we are committed for our own business operations to reach carbon neutrality by 2025.

As a company, we have been leading the way in electrification for the past 20 years, in the form of Hybrid, and since 2015 we have been working to diversify our model range into the future, to ensure we will have a vehicle and powertrain to suit every Australian, as well as our unique landscape. This includes expanding our range of powertrains that deliver low or zero emissions to suit all our customer's needs.

This is a commitment which encompasses all parts of our business, not only at the level of vehicle tail pipe emissions. We believe that a varied approach towards electrification is the best way we can help reduce carbon emissions now, as Australians have different circumstances and different needs - from inner cities to the rural outback. That is why we aim to continue to deliver a broad range of low and zero emission vehicles; such as hybrid, plug-in-hybrid, battery electric and hydrogen fuel cell electric vehicles, as well as continuing to trial hydrogen internal combustion engines and other e-fuels/biofuels.

Through our diversified approach, we aim to create value by providing our customers with the best product and experience to suit their needs - ultimately empowering Australians with the freedom to move, which also includes our ride sharing service KINTO. As part of our sustainability journey, we are also working towards decarbonising our operations by expanding our solar electricity generations, to ensure we are finding and delivering end-to-end solutions.

At Toyota Australia, our people are our greatest asset. In a post COVID-19 world, we will continue to focus on supporting our people through this challenging environment. A large focus will be on prioritising mental health, diversity and inclusion, as well as providing our people with the tools and opportunities required to develop their skillset for the future.

Through our 'people first' commitment, we also aim to enrich our community, committing 1% of our pre-tax profits towards social contribution and impact. Producing happiness also means we must meet our obligations as a responsible global corporate citizen, giving back to our community through our community trust and charity partners, making meaningful contributions and long-term investments in areas related to mobility and local needs. We will also continue our 'Good for Footy' and 'Good for Cricket' initiatives, along with National Tree Day,

providing resources and funds to strengthen the communities in which we operate.

Finally, based on our value of respect for people, Toyota is taking global action for Forced Labour of Migrant Workers in order to promote an awareness of Forced Labour at production sites. Here in Australia, we continue to challenge our suppliers to establish full transparency and traceability of their operations, managing risks by implementing a reliable procurement framework, and eliminating modern slavery practices if found.

Together with the Toyota Australia dealer network, I am confident we can create a future where we enrich our communities and create a tomorrow that produces happiness for all.

Matthew Callachor
President and CEO

Toyota Australia

What We Do and How We Create Value

Our operating environment

Mobility is going through a once in a century transformation. As the industry continues to evolve, we are guided by our Kaizen philosophy of continuous improvement to create mobility for all.

Where 2021 was focused on global health and keeping businesses operating, 2022 has seen the Australian economy bounce back. Australians are free to move about again, and with that, demand for Toyota vehicles has continued to increase.

Supply chain disruptions and rising fuel prices due to global factors continue to challenge all sectors, including the automotive industry. To continue Toyota Australia's legacy as Australia's number one* automotive brand, we know that we will need to continue to work closely with our suppliers and distribution networks on issues as they arise, including cyber threats, the war for talent and changing regulatory expectations.

*During calendar year 2021, Toyota had the highest total market share in Australia at 21.3%. Mazda had the second highest market share at 9.6%.

The transformations that continue to shape our industry include:

Connected, automated vehicles

Connected, automated vehicles are an essential component of new mobility experiences and safer, more efficient road networks. Advances in hardware and software are accelerating the evolution of the automotive industry and changing perceptions of mobility.



Sharing services

The shift from vehicle ownership to usership continues to emerge, and the sharing economy in Australia is anticipated to accelerate as COVID-19 restrictions ease and people return to moving around freely. The rising cost of living, including fuel prices, and customers' desire to reduce their carbon footprint also influence their preference for more affordable and sustainable transport alternatives.

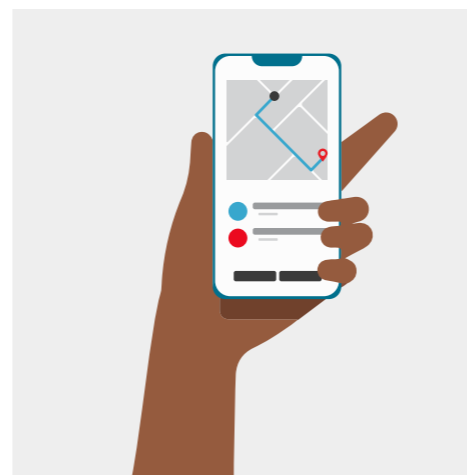

Electrification

Customers are seeking lower emissions mobility options as they seek to reduce their carbon footprints and are increasingly interested in electrified vehicles (Hybrid electric vehicle, Plugin hybrid electric vehicle, Battery electric vehicle and Fuel cell electric vehicle).

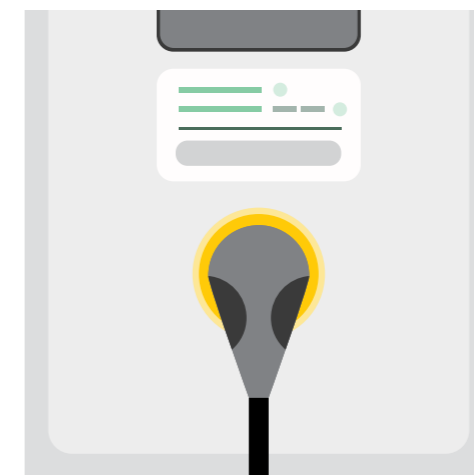

Digitalisation

Increasing digitalisation means more people are managing their lives online, and are expecting the businesses they interact with to support a seamless experience.



Our value creation model

INPUTS

What we draw on

OUR BUSINESS

Toyota brands and scale
 Toyota Philosophy, Toyota Production System, Toyota Way
 Toyota vehicles
 Staff across Toyota Motor Corporation Australia, Toyota Finance Australia and the Toyota Dealer Network

OUR PLANET

Raw materials for vehicles
 Energy, water and land for our operations

OUR COMMUNITY

Our customers, the Australian people
 Government stakeholders
 Industry partners
 Suppliers and partners

BUSINESS ACTIVITIES

How we create value

VISION

To connect us all with the freedom to move and be moved

MISSION

Producing happiness for all

WHAT WE DO

Growing existing business
 New and used vehicle sales and marketing
 Parts and accessories
 Logistics

Developing emerging areas
 Car sharing
 Connected services
 Digital services

HOW WE DO IT

Safety and trust
 Focus on quality
 Continuous improvement
 Community support and engagement
 People development

OUTPUT AND OUTCOMES

The value we create

Reimagined mobility experience

We give our customers the best product and experience, giving Australians the freedom to move

We deliver affordable, high quality vehicles and mobility options that cater to Australians' needs, whether they are individuals, businesses or fleet customers zipping around the city or traversing the rugged outback. By giving our customers quality vehicles and service, we help them to be happy and confident in their driving experience. Our digital and subscription services build personal and memorable experiences, creating Toyota fans for life.



Safer, better vehicles and technology

We build ever-better vehicles and partner with industry to innovate new technologies and develop connected infrastructure

We are reshaping the mobility landscape with expertise in new vehicle and energy technology, and infrastructure. We are helping to create safer, more connected road networks through partnerships and technological advances. Our hydrogen technology, advocacy and engagement propels energy innovation in Australia. Our philosophy means that we work continuously to improve the design of our vehicles to reduce accidents and injuries.



Reduced environmental impacts

We drive Australia towards carbon neutrality and constantly improve our processes to minimise our negative impact

Vehicle manufacture and use depletes natural resources, creates carbon emissions and pollution, and can cause environmental damage through spills. We work to reduce carbon emissions by developing low-emissions vehicles and by improving end-of-life processes. We strive to minimise the negative environmental impact of our operations through the generation and use of renewable energy. We help to improve local ecosystems with trees planted through community initiatives.



Stronger economy and thriving communities

We help keep businesses on the road and contribute to local communities to support the prosperity of the Australian community as a whole

A profitable Toyota keeps Team Toyota Australia people employed and supports local economies, including dealerships and communities. Our growing company contributes to our suppliers' economic success, and our vehicles help to keep Australian public and private sectors on the move. We help communities thrive through fundraising, education, road safety and grassroots activities.



Capable, accomplished people

We develop Team Toyota Australia, supporting them with the skills needed to navigate a changing mobility landscape

Toyota training and apprenticeship programs upskill talent across Team Toyota Australia. This helps to develop better leaders, better engineers, better dealers, and better equipped employees who feel a sense of meaning and pride in their work.



Our value creation model was created with input from our leadership team. Two workshops were conducted with our General Managers to give them an overview of integrated thinking and integrated reporting. During these workshops, they were invited to contribute to the activities, inputs, outputs and outcomes shown in the value creation model. A small number of interviews were also undertaken with General Managers to draw out further input to the value creation model.

Value created in FY22 highlights

Reimagined mobility experience

- Guest Satisfaction Index: **94.1** (sales*); **91.2** (services^)
- Net Promoter Score: **83.6** (sales*); **70.4** (services^)

* Private and Bronze Fleet sales (61,678 survey respondents)

^ Toyota Service Advantage service (100,432 survey respondents)

3,232

KINTO members

KINTO is Toyota's global mobility brand that offers car sharing and rental services to the Australian consumer

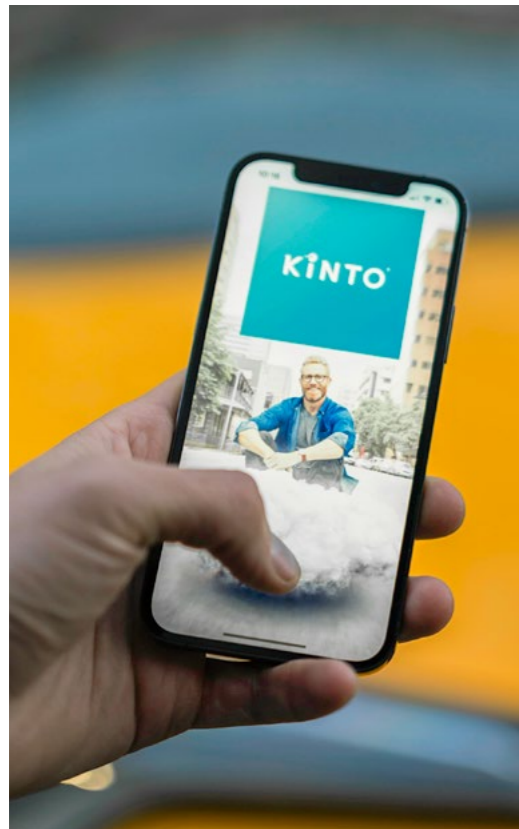

Reduced environmental impacts

- **31.1%** hybrid vehicle of total sales
- Average CO2 g/km avoided due to current HEV and BEV sales **15.1**
- **73,027** hybrid vehicles sold
- **72** Lexus battery electric vehicles sold
- **17** Mirai hydrogen vehicles leased

1,954

hybrid batteries recycled

1,846,394 kWh

solar generation



Safer, better vehicles and technology

- Continued contribution to Australian automated vehicle trials and C-ITS research
- Uplifting cyber security through the Thunderbird program



Stronger economy and thriving communities

- **\$10.1b** net sales
- **\$95.7m** tax paid
- **\$249.5m** profit after tax
- **1,246** suppliers
- **\$1.116b** total supplier spend (97.5% with Australia-based suppliers)
- **214** Toyota and Lexus dealerships, employing >17,000 people
- Dealer Satisfaction Index: Toyota: **8.45**; Lexus: **9.14** (industry average: 7.75)
- **\$3.39m** in community contributions



Capable, accomplished people

- **1,809** total Toyota Australia employees
- **29%** female representation in workforce
- Lost time injuries reduced from 38 in FY21 to **16 in FY22**

82

Employee engagement score

72

Employee enablement score

Our philosophy, values and strategy

TOYOTA GLOBAL VISION “MOBILITY FOR ALL”

TOYOTA GLOBAL MISSION “PRODUCING HAPPINESS FOR ALL”

Toyota will lead the future mobility society, enriching lives around the world with the safest and most responsible ways of moving people.

Through our commitment to quality, ceaseless innovation, and respect for the planet, we strive to exceed expectations and be rewarded with a smile.

We will meet challenging goals by engaging the talent and passion of people who believe there is always a better way.

Toyota Guiding Principles

The seven **Toyota Guiding Principles** were introduced in 1992. These principles are built upon those set out by Toyota’s founder, Sakichi Toyoda, in 1935. They set the standard for our conduct and approach to our business and engagement with our stakeholders to achieve the best outcomes for all. See [appendix](#) for more information.

Toyota Way

The **Toyota Way** is how we bring the Toyota Guiding Principles to life every day. They represent the values each Toyota teammate embeds in their work ethic and as they interact with their peers, customers and broader communities. See [appendix](#) for more details.

Toyota Environmental Challenge 2050

The **Toyota Environmental Challenge 2050** sets out six areas for global Toyota operations to focus their environmental initiatives. TMCA’s 2030 Direction and Sustainability Mid-Term Business Plan outline our specific work to address these areas, and are informed by the SDGs.

VISION – TO CONNECT US ALL WITH THE FREEDOM TO MOVE AND BE MOVED

2030 Direction

The **Toyota Australia 2030 Direction** outlines Toyota Australia’s vision to connect us all with the freedom to move and be moved and our mission of producing happiness for all. To produce value for our stakeholders and Toyota Australia, the 2030 Direction identifies strategic priority areas of digital connectivity, brand expansion, supporting employees, sustainability and contributing to the UN Sustainable Development Goals (SDGs), strengthening partnerships, and connecting Toyota Australia’s value chain to create a mobility ecosystem.

Mid-term Business Plan

The **Mid-term Business Plan** outlines Toyota Australia’s medium-term plan to achieve long-term business goals, and growing our contribution to the economy, society and environment.

Company Hoshin

Our **Company Hoshin** outlines our annual objectives and targets related to Toyota Australia’s strategic priorities, supporting the achievement of our Mid-term Business Plan. Each business unit has its own Hoshin plan, which guides decision-making and alignment of our operations with our overall strategy.

TMCA Sustainability Mid-term Business Plan

Toyota Australia’s **Sustainability Mid-term Business Plan** supports TMC’s Toyota Environmental Challenge 2050 by setting challenging medium-term targets and our roadmap towards increasing our positive impact.

Our value chain

VALUE CHAIN

Product development: research, planning and design (TMC and other Toyota affiliates)

We have 150 engineers in Australia, retaining a strong hand in designing, selecting and customising vehicles to meet the unique needs of the Australian market.

Manufacturing and conversions (TMC and other Toyota affiliates)

Toyota Australia vehicles are manufactured by TMC in Japan and Toyota affiliates in Thailand and the United States. Toyota Australia's conversions and accessories division localises powertrain development to suit local market needs.

Logistics: import, storage and distribution (TMCA and third-party logistics company)

Toyota Australia imports vehicles and sources vehicle parts both internationally and locally. Toyota Australia distributes vehicles and parts to Toyota dealerships located throughout Australia. Our Toyota Part Centres (TPCs) manage this distribution and work to reduce their environmental footprint by improving packaging recyclability.

Sales and marketing (Toyota Australia)

Toyota Australia promotes the Toyota and Lexus brands through marketing and communication channels, particularly through our trusted dealer network. We serve fleet customers directly through Toyota Australia or our specialised fleet dealerships.

Vehicle use (Toyota Australia customers)

The One Toyota Network Toyota Australia and Toyota Finance Australia with our partners aims to provide end-to-end service throughout our customers' Toyota journey, including customer service, sales, finance, insurance, and vehicle servicing.

End of life: used vehicles (Toyota Australia and third parties)

Customers can purchase Toyota Certified Pre-Owned Vehicles, which provides Toyota certified pre-owned warranty, instant car valuation and Toyota genuine service to support their peace of mind.

We also recycle the batteries from hybrid vehicles, with battery recycling incentives offered through our Toyota and Lexus dealers around Australia. We aim to promote and reinforce effective recycling to limit our impact on global resources and landfill.

STAKEHOLDERS

- TMC
- Customers
- Environment



Providing flexible and practical mobility options to suit all customers' needs.

Reducing vehicle carbon emission through research into and design of low carbon vehicles. See page 27 the **TMC Sustainability Data Book** for more information.

- TMC
- Suppliers
- Environment



Producing high quality and diverse vehicle line up to suit the Australian market.

Carbon emissions from manufacturing contribute to climate change. Potential social and environmental impacts of raw materials and supply chain.

- Dealers
- Employees
- Customers
- Environment



Supporting Toyota and Lexus dealers to provide products to our customers.

Providing employment in Australia to people working across our TPCs.

Vehicle shortages and supply chain delays can leave customers dissatisfied with their Toyota experience.

Emissions from heavy vehicle logistics.

- Employees
- Customers
- Government
- Environment



Providing employment in Australia to people working in Toyota Australia's offices

Providing customers with products, services and information to meet their mobility needs.

Providing mobility solutions to customers to move them where they need to go, while raising awareness of increasingly available electrified options.

Marketing activities also contribute the highest amount to our operational carbon footprint.

- Customers
- Community
- Environment



Providing mobility solutions to customers to move them where they need to go.

Growing presence of Toyota and Lexus hybrid and electric vehicles reduce environmental impacts from vehicle use.

Vehicles can be involved in accidents that harm customers or the community.

Toyota vehicles on Australian roads can have environmental impacts through tailpipe emissions.

- Customers
- Environment



Customers benefit from their vehicles retaining value and affordable pre-owned options.

Hybrid battery recycling supports circular economy to protect the environment.

Vehicle waste can contribute to poor environmental outcomes.

IMPACTS



Our stakeholders

Understanding and collaborating with our stakeholders is critical to our business success and delivering a broader positive impact. Engaging with our stakeholders allows Toyota Australia to understand issues that are important to them. We connect and share our vision with our stakeholders through open communication, collaboration, education and advocacy.



Customers

We are committed to delivering an exceptional customer experience through every interaction. We gather our customers' feedback through our dealers and online surveys to understand how we can keep doing better. By embracing digitalisation, we can deepen our connection to customers and provide a seamless Toyota experience through our digital services such as the MyToyota and KINTO apps. Customer communication and satisfaction is supported through our in-house call centre. Our marketing and advertising campaigns keep customers up-to-date with the latest Toyota offerings, and alerts drivers of recalls to keep our roads safe with the support of our Guest First division.



Community

Giving back to the community is an integral part of the Toyota Guiding Principle of respecting the culture and customs of every country and region, and contributing to economic and social development through corporate activities. We engage with the Australian community and strive for a positive social impact through the Toyota Community Trust (TCT), Toyota Production System Support Centre (TSSC) and supporting STEM education for Australians.



Dealers

The Toyota Australia dealer network is vital to our business, and they are our customers' primary touch point. We support dealers' operations through regular communications, training programs and events, our annual National Dealer Conference, and the National Toyota Dealers Association.



Employees

Toyota employees are the foundation of Toyota Australia's business success. We communicate Toyota news and updates through our intranet and employee bulletins, and encourage employees to engage with us and share their ideas through the Toyota Torque town halls. We also provide opportunities for career growth through forums, training, internal rotations and performance reviews to develop their skills. Our annual Employee Engagement and Enablement survey is a valuable channel through which Toyota Australia listens to our employees' concerns and ideas.



Government

Working with governments is critical to delivering the safest and most sustainable mobility for Australians. Our Government Affairs team closely monitors policies, issues and developments related to our sector so we can constructively engage with governments. We support governments to enhance road networks through research, connected vehicle trials, road safety initiatives, and through our contribution to policy discussions through Toyota Australia and Federal Chamber of Automotive Industries (FCAI) advocacy.



Environment

The Toyota Environment Challenge 2050 and the Toyota Sustainability Mid-term Business Plan direct our commitment to reducing our environmental impacts, and Toyota Australia takes a particular focus on driving progress towards carbon neutrality across our value chain. Our environmental initiatives are complemented by our involvement in organisations such as Planet Ark, Green Building Council Australia, and the Business Council for Sustainable Development.



Suppliers

Our suppliers are an essential part of our value chain and play a crucial role in our ability to deliver for our customers. Having strong relationships with our suppliers is especially important as our business model shifts in response to industry trends, and potential human rights abuses and negative environmental impacts in our supply chain. We maintain strong relationships with our supplier partners through Toyota Australia supplier relationship managers, with the aim of balancing the needs of both Toyota Australia and our partners.

TOYOTA

Toyota Motor Corporation

As the parent company of Toyota Australia, TMC plays an active role in our business, from representation on our Board to TMC 'inpatriates' who work alongside our operational arm leaders and liaise closely with TMC. To align and streamline our operations, we regularly connect with TMC on policy development, strategy, product planning and sharing best practice.

Our material topics

Material topics are matters that substantively affect our ability to create, preserve or erode value for our business and our stakeholders over the short, medium and long term. We undertake a materiality assessment annually that includes consideration of risks and opportunities related to material topics, both within and outside of

Toyota Australia’s direct control. Our assessment is guided by reporting frameworks such as the <IR> Framework, the GRI Standards, UN SDGs and related guidance.

Following a comprehensive assessment including stakeholder engagement in 2021, the 2022 assessment involved a desktop review of internal documents including strategies, policies and

communications, and external publications such as reports and articles from our peers, industry bodies, non-government organisations and the media. It was also informed by interviews with internal stakeholders, although these were not primarily focused on materiality.

The resulting material topics are presented below left.

Material topics

Value created	Material topic	Page
Reimagined mobility experience	Customer preference and satisfaction	13
	Shared services	14
Safer, better vehicles and technology	Product safety and quality	15
	Connected and automated vehicles	16
	Data privacy and security	18
	Strategic partnerships	19
	Advocacy and regulatory engagement	19
Reducing environmental impacts	Lower carbon mobility, including electric, hybrid and hydrogen vehicles	20
	Vehicle lifecycle	23
	Operational environmental impacts	23
Strong economy and thriving communities	Indirect social and economic impacts	27
	Supply chain risk	28
	Dealer network	30
	Community investments and partnerships	32
	Skillsets for the Australian community	34
	Regional engagement	35
Capable, accomplished people	Workforce engagement and communication	37
	Workforce skills and development	38
	Diversity and inclusion	40
	Employee health, safety and wellbeing	42
Enabling factor across multiple thematic areas	Innovation	Throughout report

Our impact

Guided by the Toyota Philosophy, we believe in being a responsible corporate citizen and strive to create a positive impact on our stakeholders and the environment. This is embedded in our culture and values. Our proprietary Toyota knowledge, technology and innovation, strategic partnerships, advocacy, and community initiatives support this aim.

Toyota Australia’s priority SDGs

Goals and alignment with strategy



Working towards net zero emissions in line with our electrification strategy

SDGs



Managing our product lifecycle by optimising our value chain

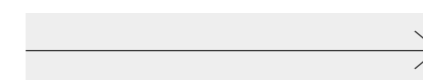

Creating infrastructure for mobility as we transition to a mobility company

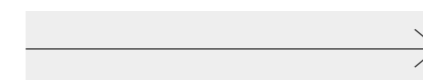

Assisting to advance the transport infrastructure in Australia, improving STEM opportunities for women



Policy advocacy and community education activities



Our approach to impact is informed by Toyota Australia’s priority SDGs, which guide the activities we undertake to make a positive contribution to Australian communities and our environment.

In FY21, Toyota Australia began work to identify the SDGs on which we can have the greatest impact through our business strategy and activities. In FY22, we built on this work by assessing our potential pathways for creating impact and developing a set of indicators to measure and track our progress against these material outcomes. Our next step is to develop an action plan to work towards the material outcomes, then measure and track progress using the indicators, with the intention to report on our progress in future sustainability reports.

External memberships and associations

Toyota Australia is a member or signatory to the following organisations:

- [Australian Hydrogen Council](#)
- [Australian Industry Group](#)
- [Business Council for Sustainable Development \(Australia\)](#)
- [Committee for Economic Development of Australia](#)
- [Committee for Melbourne](#)
- [Federal Chamber of Automotive Industries \(FCAI\)](#)
- [Intelligent Transport Systems Australia](#)
- [Australasian Fleet Management Association](#)
- [CitySwitch Green Office program](#)
- [Green Building Council Australia](#)
- [Philanthropy Australia](#)

Toyota Australia is aligned with a range of external charters and principles in addition to our own. These include:

- Australian Hydrogen Council
 - Social Licence Principles
 - Regulatory Principles
- Environmental Management System ISO14001 (Port Melbourne Office and Altona Toyota Parts Centre)
- Federal Chamber of Automotive Industries (FCAI) Codes of Practice for:
 - Access to service and Repair Information for Motor Vehicles
 - Conduct of an Automotive Safety Recall
 - Motor Vehicle Advertising
 - Recycling of Traction Batteries
 - Automotive Data and Privacy Protection
 - New Vehicle Receiving and Inspection Procedures
 - Electromagnetic Compatibility Code
 - Technical Statement on EV Charging Standards for Public Recharging infrastructure
- Occupational Health and Safety (OHS) National Audit Tool for OHS Management Systems OHS ISO18001
- Self-Insurance (Victoria)

Governance

Toyota Australia's governance structure

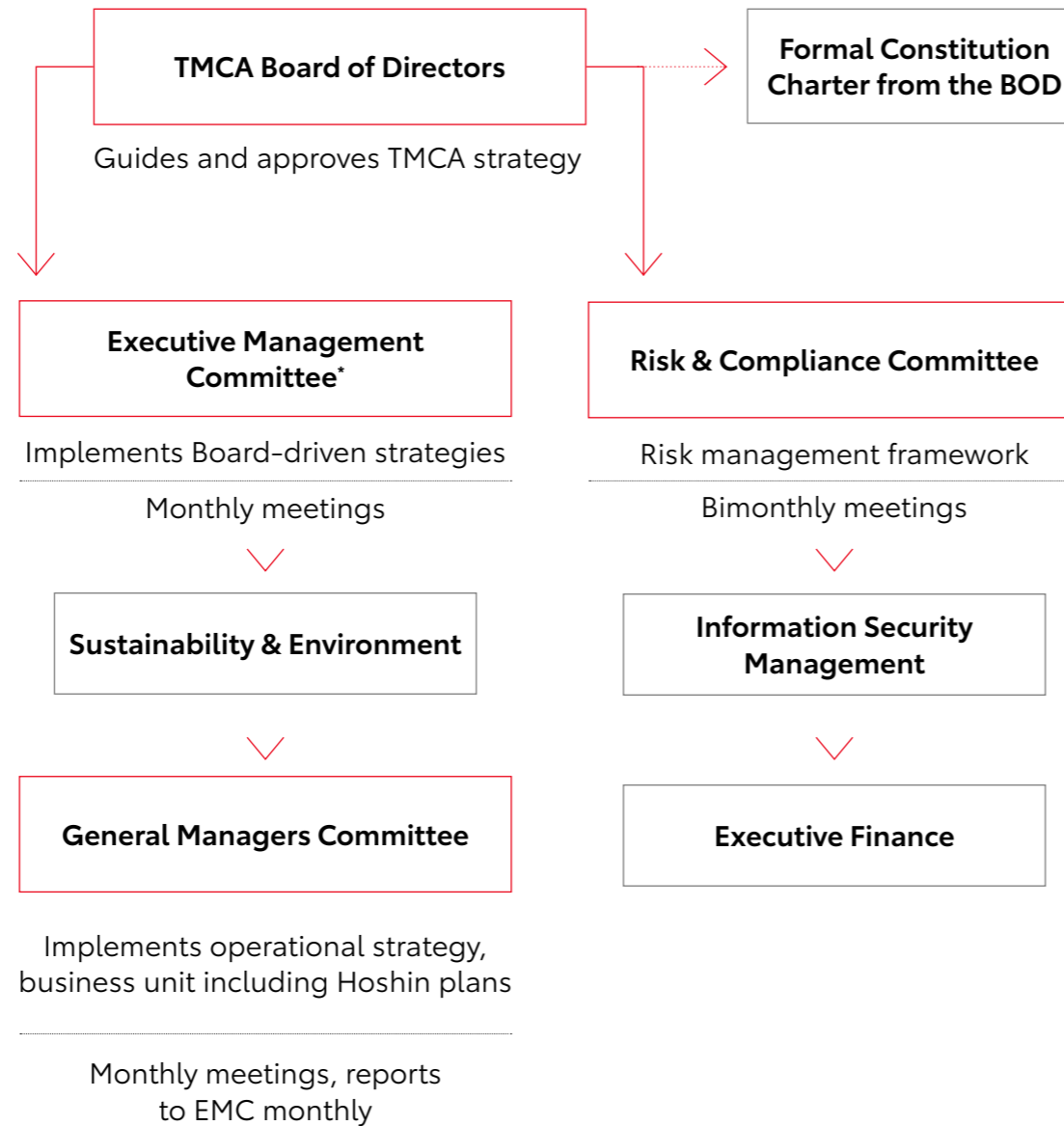

*The former Sustainability & Environment Committee was integrated into the Executive Management Committee in FY22.

Board composition

During the reporting period, four Directors resigned, and three joined the Board of Directors. Evangelos Tsirogiannis stepped down, while Nobuhiko Murakami, Takuo Muto and Scott Michael Thompson resigned as part of TMC global rotations. Scott Michael Thompson will continue to work closely with Toyota Australia as a non-executive member of the Executive Management Committee.

This change reinvigorates the Board and will enable Toyota Australia to bring new insights and knowledge to our strategic objectives and operations in 2022. The Directors are listed below as at 31 March 2022. The Board met three times during the reporting period. For more information on Toyota Australia's Directors, see [Appendix](#).

Current Directors

Name	Role	Appointment date
Matthew Callachor	Toyota Australia President and CEO	1 June 2016
Michael Rausa	Vice President, Guest, Aftersales & Corporate Operations	1 January 2021
Sean Hanley	Vice President, National Sales & Marketing Operations	1 January 2021
Akitoshi Takemura	Chair and TMC Regional CEO (East Asia, Oceania & Middle East Region)	1 January 2022
Kane (Takayuki) Kanno	Vice President, New Business Solutions & Product Planning Operations Chief Coordinating Executive	1 January 2022
John Pappas	Vice President, Information & Digital Services Operations Chief Executive, Lexus Australia	1 January 2022

Former Directors

Name	Appointed	Resigned
Nobuhiko Murakami	1 January 2018	31 December 2021
Takuo Muto	9 March 2021	31 December 2021
Evangelos Tsirogiannis	1 January 2021	17 May 2021
Scott Michael Thompson	1 January 2021	31 December 2021

Toyota Australia governance committees

Committees

	Meeting frequency	Members	Responsibilities
Executive Management Committee (EMC)	Monthly, chaired by the President and CEO	Executives and non-executives team members from across business areas, e.g., Company President, Treasurer, and Vice President of Guest and After Sale, Finance and Corporate Operations	<ul style="list-style-type: none"> • Decision making and endorsement • Implement major company projects • Monitor key organisational structural changes • Provide input into and approval of Toyota Australia’s strategic direction and budgets • Direct, monitor and assess Toyota Australia’s performance against strategic and business plans • Approve and monitor capital management • Receives monthly reports from GMC on operational issues related to Hoshin plans, including sustainability
Risk and Compliance Committee (RCC)	Bi-monthly meetings and reviews of Toyota Australia’s risk management framework and risk registers	Six senior Toyota Australia members and Toyota Australia Vice Presidents chair chairs the committee	<ul style="list-style-type: none"> • Assist the Board to fulfil its risk management and oversight responsibilities • Act with due care and diligence in relation to: <ul style="list-style-type: none"> - Risk management, including risks related to sustainability - Internal and external audits - Compliance and maintaining ethical standards - Fraud - Information security management
General Managers Committee (GMC)	Monthly, approximately one week before reporting to the EMC	General Managers from across Toyota Australia’s business units	<ul style="list-style-type: none"> • Ensure collaboration and strategy alignment across divisions • Monitor and manage the implementation of strategic company-wide projects • Manage resources to support Hoshin and Company projects • Translate operating Hoshin into divisional strategies and priorities, including regarding Toyota Australia’s sustainability strategy • Provide forum for operational issues to be escalated for higher consideration • Facilitate learning and cross divisional collaboration

In FY22, Toyota Australia elevated sustainability’s strategic priority within our organisation, integrating the former Sustainability and Environment Committee into the EMC. Sustainability is now embedded in our executive agenda, and factored into key decision-making and strategy development. While we have always made strong commitments to sustainability, we expect that this structural change will improve our sustainability performance and accountability beyond ad hoc projects to a more integrated and strategic approach across the entire business.

As part of this transition, the Sustainability and Environment Committee met for the final time in October 2021 before its functions were fully integrated into the EMC. All members of the former SEC now sit on the EMC. The EMC holds a dedicated meeting on sustainability every six months.

To further embed sustainability into every level of our operations and decision making, the Toyota Australia 2030 Direction and corporate Hoshin plan now include sustainability as a key strategic priority for business success for the first time. The GMC is responsible for monitoring implementation of Hoshin activities and achievement in our key objectives.

Progress towards carbon neutrality is a priority goal of the Toyota Environmental Challenge 2050. Our governance framework to drive our decarbonisation corporate strategy is shown below.

Sustainability governance framework



TMCA Reporting

2030 Reporting	Executive Management Committee	Risk & Compliance Committee
Monitor long term direction Monthly report	Monitor short and medium term direction Monthly report Biannual sustainability presentation	Toyota Environmental Management System (TEMS) compliance Bimonthly risk report

Corporate policies

Toyota Australia corporate policies are guided by our business strategy, which is developed and approved by management and the Board of Directors. They support Toyota Australia to execute these strategies and achieve our mission.

Policies

- Code of Ethics
- Risk Management Policy and Procedure
- Conflict of Interest Policy
- Fraud and Corruption Control Policy
- Health and Wellbeing Policy
- Diversity and Inclusion Policy
- Environment Policy
- Procurement Policy
- Procurement Engagement Policy
- Supplier Use Procedure
- Supplier Minimum Standards
- Anti-Modern Slavery Procedure
- Whistleblower Protection Policy

All employees have access to our policy platform with the most up-to-date information to promote and enable compliance. To ensure our actions are aligned with our responsibilities and values across the business.

Additionally, all professional employees receive formal training on our Conflict of Interest, Fraud and Corruption Control, Code of Ethics, Whistleblower Protection and Modern Slavery Policies every two years. This ensures they are able to

work in line with Toyota Australia’s values and commitments, identify scenarios which would breach our policies and understand their obligations to disclose where they may have a conflict of interest.

We manage our regulatory and ethical compliance through our Risk and Compliance Committee, which maintains both the risk and compliance registers. Our compliance register monitors suspected and actual reports of non-compliance incidents, and tracks their status from actions taken to when investigations are finalised and incidents are closed. There were no incidents of corruption in FY22. Toyota Australia also faced no legal actions for anti-competitive behaviours, in line with our commitment to ethical business conduct.

In March 2022, we had two instances of environmental regulatory non-compliance relating to one event at our Altona facility. Wash water containing paint and plaster residue was discharged to the trade waste system which was reported to the water authority, Greater Western Water. The wash water was also accidentally discharged to the stormwater system and to an outfall containment area. This was immediately notified to Environmental Protection Authority and also Melbourne Water. The spill was contained and remediated quickly, and the wash bay was decommissioned. The nearby Kororoit Creek was not affected by the spill.

We are committed to promoting integrity and ethical conduct. If current or former employees and contractors, or their family members, have concerns about Toyota Australia’s business conduct, they can contact a third party-operated whistleblower hotline without fear of reprisal.

Reimagined mobility experience

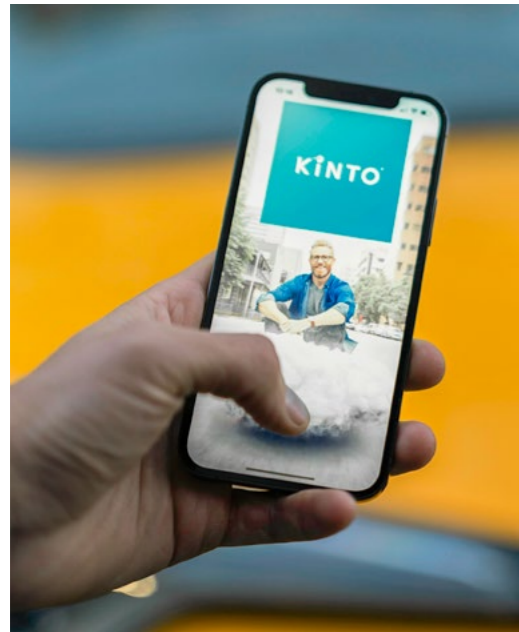

Our ambition

As Australia's most trusted automotive brand, Toyota is known for affordable, high-quality vehicles and mobility options that cater to all needs, from individuals to corporate and fleet customers. Our vehicles and shared services offer personal and memorable mobility experiences, giving our customers confidence in their interactions with Toyota. We create value by providing our customers with the best product and experience, empowering Australians with the freedom to move.

Customer preference and satisfaction

Customer loyalty propels our business. We strive to fulfil our customers' diverse needs and drive this loyalty by enabling our customers to pursue what they love through our products and services. From designing and delivering the right vehicle for Australians, to supporting our fleet customers with reliable vehicles and convenient service, we put our customers' needs first at every stage of their Toyota experience. Toyota Australia, TMC and our network of 275 Toyota and 30 Lexus dealer sites provide timely and efficient service to our customers, from when they order their vehicle until its end of life.

We have over four million customers across Australia, and almost half of our vehicles are sold to corporate and fleet customers. Toyota Australia strives to maintain the highest level of customer satisfaction to continue building our fleet sales which supports the broader Australian economy by keeping business on the move. See [p. 27](#) for more information.

Vehicle choice

To fulfil our vision and mission, we strive to offer our customers a range of diverse vehicle and powertrain options to suit their preferences and lifestyles, whether they are zipping around the city or traversing Australia's rugged outback.

We know that our customers want to align their mobility choices with what is important to them, which increasingly includes sustainability. This is why we are bringing new low and zero emissions models to the Australian market, including a wider range of hybrid electric vehicle (HEV) models than ever before, and our upcoming battery electric vehicle (BEV) as part of Toyota's global Beyond Zero (bZ) line-up. We also offer an electrified vehicle for the luxury market: the Lexus UX300e. To promote lower emissions vehicles, we leverage our brand and reputation through marketing campaigns. We also ensure all dealership staff have the knowledge needed to help our customers understand the benefits of lower emissions vehicles through training. This is reflected in our sales results, with 93% of the hybrid market share in Australia as at 31 March 2022. HEVs are powered by a combination of an internal combustion engine and electric motors. These two power sources are able to operate independently of each other. This means the electric motor can power the car on its own for short distances, up to 50km/hr when charged.

At the same time, we recognise that current electrified technologies may not suit everyone's mobility needs, especially when it comes to heavier vehicles needed for work or to travel vast distances across the country, where electric charging infrastructure is not yet widely available. Internal combustion engine vehicles (ICE vehicles) form

part of Toyota's vehicle line-up alongside HEVs and BEVs, to make sure all our customers can get where they need to go. See [p. 20](#) and [p. 24](#) for more information on how we reduce the negative environmental footprint of petrol and diesel powertrains.

Our growing range of connected and automated services available in selected new models provide further choice and create safer and more seamless mobility experiences. See [p. 16](#) for more information.

Our market share of HEV sales in FY22

HEV Sales by original equipment manufacturer (OEM) (12 Month Rolling)

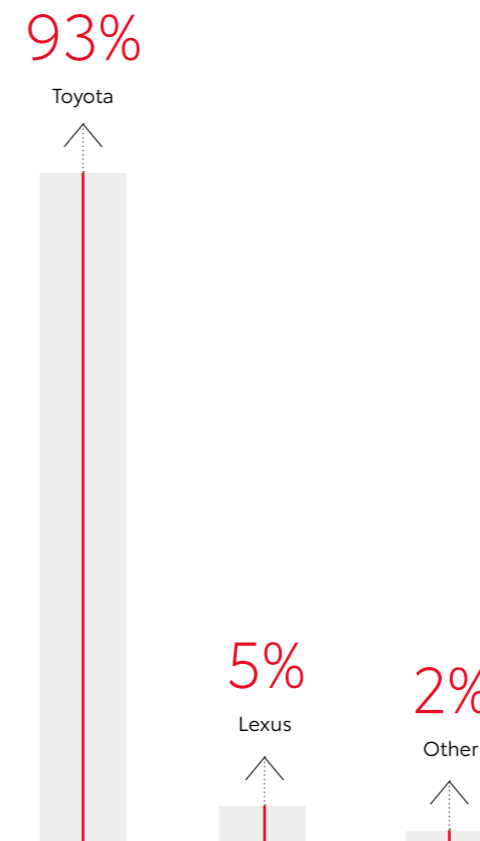

Customer service

Solving our customers' mobility problems is a priority to Toyota Australia and is a key pillar of our 2022 Hoshin. We remove our customers' 'pain points' by improving our One Toyota network to produce a seamless end-to-end experience. This includes collaboration between Toyota Australia, Toyota Financial Services (TFA) and Toyota dealers to provide support from vehicle delivery, financing, insurance and servicing.

Toyota Australia employees and dealership staff receive regular training on serving our customers and solving any problems which may arise. We also continuously improve how we communicate updates to our customers, such as estimated delivery timeframes for ordered vehicles. This is especially important as the automotive industry and other goods industries face extended supply delays and disruptions as a result of global parts shortages and COVID-19. These delays are disappointing for our customers and could have a negative impact on their experience and erode trust in the Toyota brand.

In FY22, Toyota Australia established a cross-divisional team to improve communication to our dealers and customers, and improve our processes to minimise customer wait times. Where customers need access to a vehicle sooner than their order can be delivered, we provide the option to rent KINTO vehicles to help them continue to move. For more

information on vehicle delays, see [p. 28](#) and [our website](#).

In FY22, 530,494 customers were asked for feedback with responses from 31%. This was up from 134,406. This feedback is critical to guiding us towards better customer service.

Customer experience survey results

	FY22	FY21
Net Promoter Score (sales*)	83.6	82.7
Net Promoter Score (service^)	70.4	70.5
Guest Satisfaction Index (sales*)	94.1	94.0
Guest Satisfaction Index (service^)	91.2	91.0

* Private and Bronze Fleet sales (61,678 survey respondents)

^ Toyota Service Advantage service (100,432 survey respondents)

Shared services

One of the major trends shaping mobility is the shift from personal vehicle ownership to vehicle usership, as Australians search for affordable and convenient ways to move. While interest in shared services decreased during the pandemic, we expect the trend will change as customers search for affordable and convenient mobility.

As usership gains popularity, personal vehicle ownership rates may decline, impacting vehicle sales. In response to this, Toyota is embracing usership by diversifying our business through KINTO. We are adjusting our business model to focus on new forms of mobility while simultaneously growing our existing business. We are strengthening our business and supporting the One Toyota Network during this era of transformation.

Shared services and the future of mobility

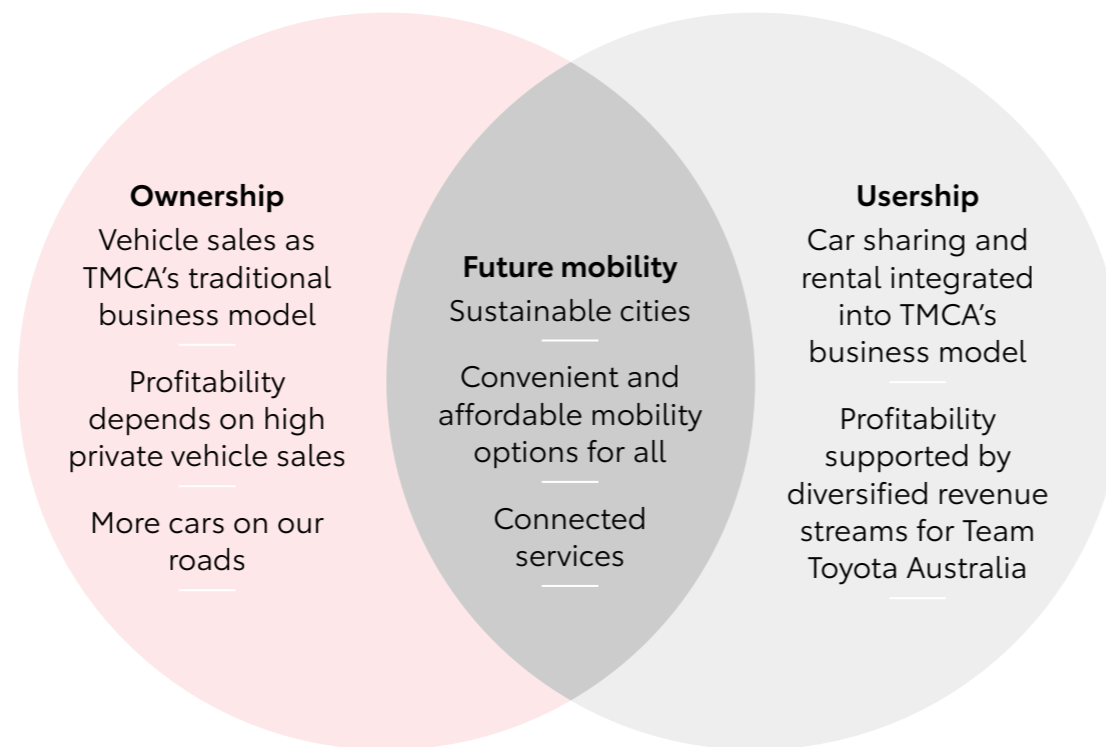

KINTO





KINTO is Toyota's global mobility brand which has launched car sharing and rental services into the Australian market. KINTO offers customers access to Toyota vehicles beyond traditional purchase or financing options, giving them the freedom to move in ways that suit their individual and changing needs. In Australia, KINTO RENT, launched in June 2021, is a collaborative effort with Toyota Dealers where vehicles can be rented off-street or from Toyota Dealers. KINTO SHARE, launched earlier in 2021, provides members with access to Toyota vehicles on-street around the clock. From initial launch in March 2021 to the end of FY22, KINTO membership increased from 500 to 3232 members.

Regular KINTO users typically do not own their own vehicles, and have reported that they benefit from flexible access – KINTO vehicles are available to our customers for pick-up and drop-off at selected on- and off- street locations, and participating Toyota dealers - and convenient booking and account management through the KINTO Australia app. We have received positive feedback since the launch, and will continue to develop our KINTO services in response to customer feedback, including our app's capabilities.

Toyota dealers are a key player in the KINTO ecosystem. Their involvement helps strengthen their businesses by deepening their customer

relationships and diversifying their revenue streams. We expect that this will increase dealerships' resilience to market shifts towards usership and direct-from-manufacturer supply, which could reduce vehicle sales volume in the future.

Kinto is:

- 
Accessible Easy access from selected Toyota dealer sites, on-street and off-street locations
- 
Affordable No membership fees or hidden charges
- 
Flexible Flexible rental timeframes, hourly, daily, weekly, monthly (up to 364 days)
- 
Holistic Includes servicing, Toyota Insurance and Roadside Assist
- 
Environmentally sound Hybrid options, with future goals for an entirely hybrid KINTO passenger vehicle fleet

For more information about KINTO, see [our website](#).

Safer, better vehicles and technology



Our ambition

Evolving from an automotive company to a mobility provider means Toyota must reimagine how vehicles can empower us to live our lives safely and effortlessly, beyond moving from A to B. Innovation is at the heart of Toyota's vision of mobility for all, where mobility solutions pre-empt our customers' needs and take the hassle away. We create value for all Australians by building ever-better vehicles and partnering with industry to innovate new technologies and develop connected infrastructure.

Product safety and quality

As Australia's largest automotive brand, the safety and quality of our vehicles is critical to the safety of all road users and pedestrians. Safety issues can undermine our trusted brand and expose us to regulatory risks if we do not act quickly to rectify problems when they emerge. This is why proactive safety and quality management is central to what makes Toyota unique.

Customers trust that buying a Toyota means buying quality. All new Toyota vehicles come with the Toyota Warranty Advantage, which offers a five-year manufacturer warranty and meets all consumer guarantees under Australian Consumer Law.*

* Disclaimer: The standard Toyota Warranty Advantage period is five years, with unlimited kilometres, from delivery. Excludes vehicles used for a commercial purpose, such as taxis, hire vehicles and vehicles transporting people or goods for payment including rideshare. The commercial vehicle Toyota Warranty Advantage period is five years from delivery or 160,000kms (whichever occurs first). See toyota.com.au/owners/warranty or your vehicle's Warranty and Service Book for T&Cs. This warranty does not limit and may not necessarily exceed your rights under the Australian Consumer Law.

We envision a future free from road-related casualties and work constantly to improve vehicle and driving safety. This includes increasing our range of connected and automated features, and advocating for government investment in infrastructure to enable these developments across Australia. See [p. 16](#) for more information.

TMC's global approach to **Real-world Safety** takes data from real-world accidents to understand vehicle factors that could have contributed to these accidents, and improve Toyota vehicle design. This includes simulating accidents to test prevention measures before incorporating them into vehicle designs.

Recalls

When we identify safety or other flaws in existing models, we act quickly to remove these vehicles from our roads. We are committed to fast recalls in line with our responsibilities under Australian Consumer Law and the Federal Chamber of Automotive Industry's Code of Practice for automotive safety recalls. To ensure we keep all affected customers safe, we communicate recalls and faults across many channels, including on the Toyota Australia website, through dealer notifications, press advertisements, letters to customers, and government notifications.

During FY22, 228,097 Toyota and Lexus vehicles were involved in 13 recall campaigns due to potential faults. Ongoing recalls from previous years also continued to be resolved. The Department of Infrastructure, Transport, Regional Development and Communications website contains all recall information, by category and brands. See www.vehicle recalls.gov.au for more information on current recalls.

HiLux, Fortuner and Prado diesel particulate filter (DPF) class action

At the time of writing, there is a class action in Australia relating to diesel particulate filters in certain HiLux, Fortuner and Prado vehicles with a 1GD-FTV or 2GD-FTV diesel engine. This fault results in increased wear and tear on engines, decreased fuel efficiency and increased exhaust. In October 2018, Toyota Australia contacted all owners of potentially affected vehicles to inform them of the fault and that they could bring their vehicles to us at their convenience so that we could replace faulty DPFs free of charge.

In 2019, Toyota Australia faced a class action associated with this fault, with legal proceedings commencing in 2019.* On 7 April 2022, a first instance judgment was handed down in favour of the Applicants. Toyota Australia is required to pay damages of \$18,401.76 to the lead Applicant. The Court found that Toyota Australia is also required to pay damages for reduction in vehicle value due to the fault and excess GST to eligible group members. Toyota Australia filed an appeal in June 2022,* and the legal proceedings are ongoing.

* Federal Court Proceeding No. NSD1210/2019

* Federal Court Proceeding No. NSD462/2022

Takata airbags class action

Since 2013, Toyota Australia has been voluntarily recalling certain Toyota and Lexus vehicles produced between 2000 and 2016 due to

them being fitted with potentially faulty Takata airbag inflators. Approximately 100 million vehicles from multiple automotive companies globally were affected. Globally, there have been 32 reported deaths and over 350 injuries associated with the fault.

A class action began in November 2017,* alleging that, in importing, marketing and supplying certain Toyota and Lexus vehicles fitted with certain Takata airbags in Australia, Toyota Australia:

- Failed to comply with the merchantable quality guarantee in the Trade Practices Act 1974 (Cth) or acceptable quality guarantee in the Australian Consumer Law
- Engaged in misleading or deceptive conduct
- Engaged in unconscionable conduct.

Other car brands included in the Takata proceedings include Honda Australia Pty Ltd, Mazda Australia Pty Ltd, Nissan Motor Co (Australia) Pty Ltd, BMW Australia Ltd, Subaru (Aust) Pty Ltd and Volkswagen Group Australia Pty Ltd.

Toyota Australia and all other parties, with the exception of Volkswagen, entered into a settlement agreement in August 2021 which has been approved. The approval hearing is scheduled for 29 June 2022.

* New South Wales Supreme Court Proceeding No. 2017/00340824

Connected and automated vehicles

Our lives are becoming increasingly connected, from smart phones to smart homes. Increased digitalisation enables us to develop connected and automated vehicles for a seamless, safe and integrated driving experience. It also means we can expect greater competition as new players enter the industry from digital backgrounds. While we prioritise maintaining our market position, we also acknowledge the need for cooperation with others in our space. Knowledge-sharing with other automotive companies, digital technology providers and governments will support cohesive connected and automated systems that work for the Australian community.

Cooperative Intelligent Transport Systems (C-ITS)

One of the key ways we deliver value for Australians is by developing cohesive infrastructure for safer, more connected and efficient road networks. Toyota Australia is at the forefront of cooperative intelligent transport systems (C-ITS) development in Australia. We collaborate with state governments in safety research and the C-ITS technology trials. Connected and automated vehicles, linked through C-ITS, have the potential to make roads safer for all. They can warn drivers about road hazards, reduce the risk of accidents from human error, reduce carbon emissions and improve road network efficiency

by using real-time information to reduce congestion.

Lexus Australia was awarded the 2021 ITS Australia Connected and Automated Vehicle Award for its C-ITS research for the Ipswich Connected Vehicle Pilot, which was part of the Queensland Government's Cooperative and Automated Vehicle Initiative (CAVI). The Award celebrates excellence and progress in C-ITS technologies that will improve our roads. See [Toyota Australia's 2021 Sustainability Report](#) for more information on past C-ITS trials and partnerships.

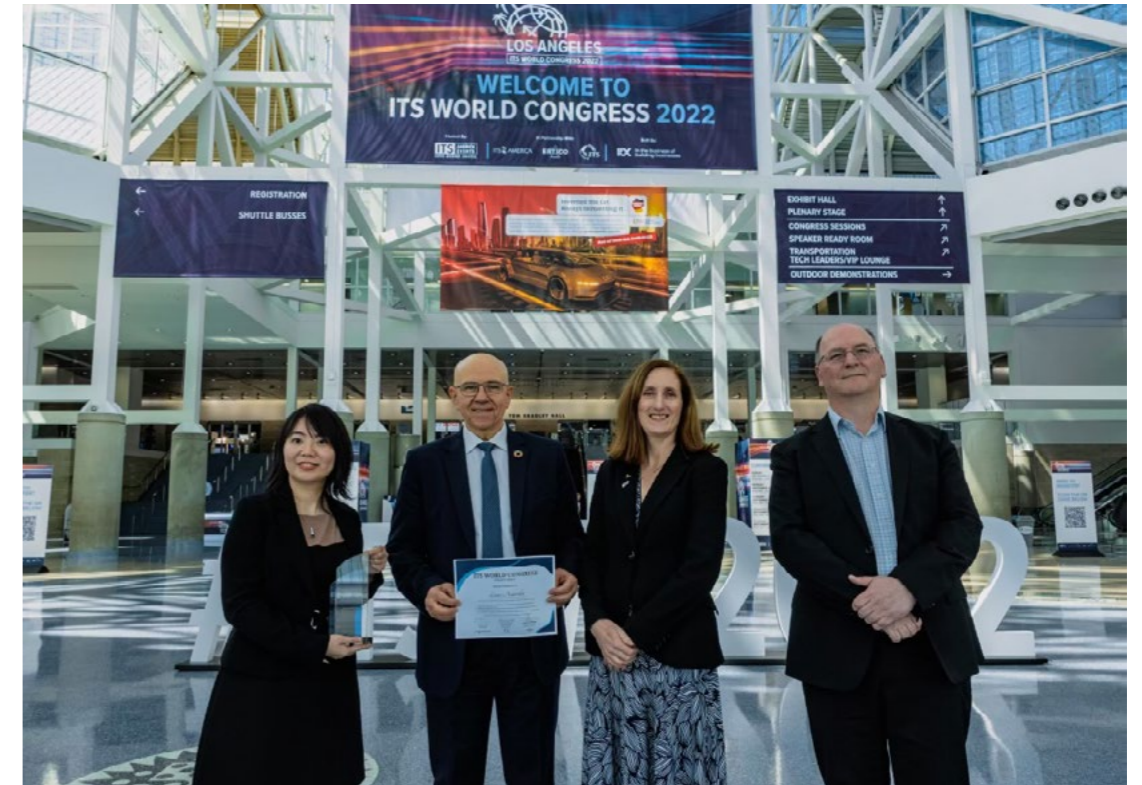

Safer roads through C-ITS

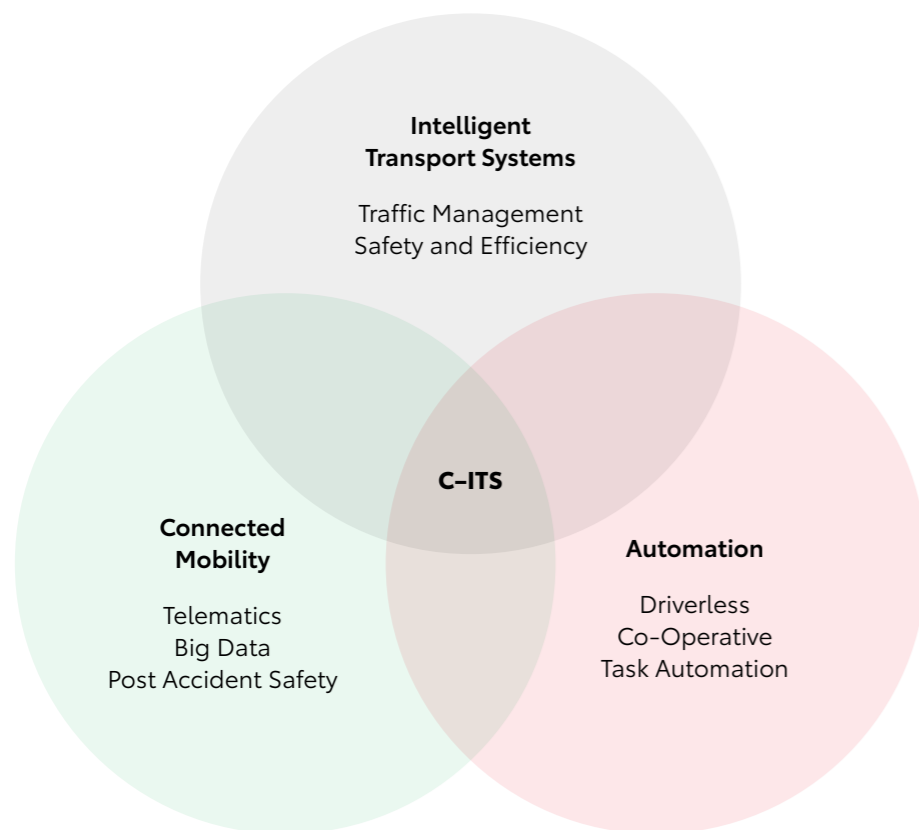

Cooperative Intelligent Transport Systems (C-ITS)

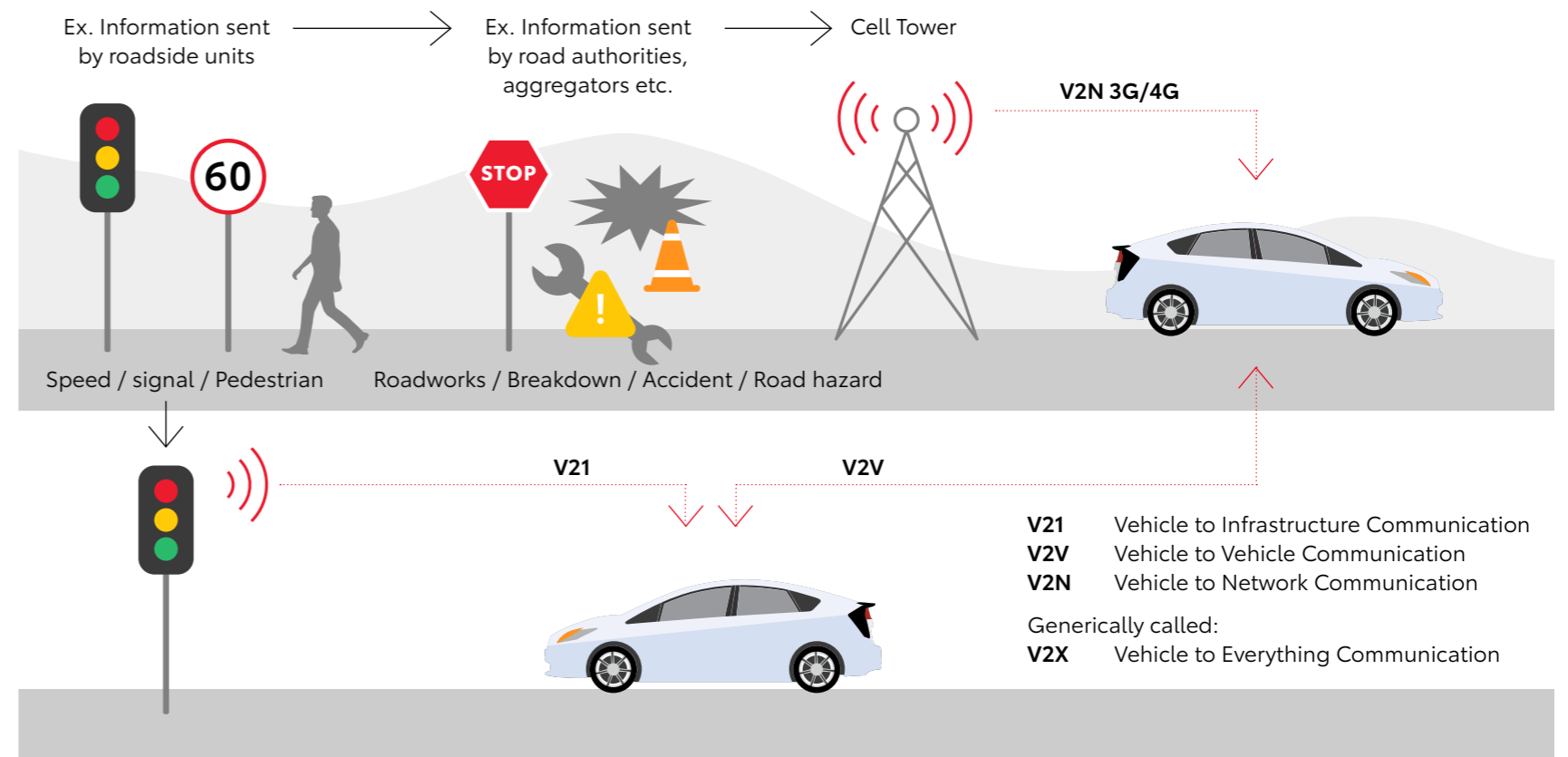

CASE STUDY

Lexus Australia joins the Australian Integrated Multimodal EcoSystem (AIMES) trials

In FY22, Toyota Australia participated in new pilot programs through AIMES trials in collaboration with industry partners, governments and academia across Australia. Lexus Australia joined the AIMES program in July 2021 to accelerate C-ITS research for smarter and safer roads, in partnership with the University of Melbourne. Toyota Australia committed \$1.7 million to this trial, though the full amount was not spent due to the project's shortened duration.

The trial tested road infrastructure-to-vehicle, vehicle-to-emergency vehicle and public transport-to-vehicle communication technologies in Carlton, Victoria. The trial involved verifying the safety applications of C-ITS functions in connected Lexus vehicles, including features like Advanced Red-Light Warning (ARLW), Turn Warning Vulnerable Road User (TWVR), Emergency Service Vehicle Notification (ESVN), Tram Awareness Alert and Tram Passenger Warning.

The data and results of the AIMES trials were published publicly for the first time in FY22. We hope this knowledge sharing will accelerate the adoption of C-ITS technology and support academic research for real-world application. Read more about these trials on the [AIMES website](#).



Our connected services

Toyota's connected services offer customers a range of technologies to support seamless driving, which are personalised, flexible and can be updated as our offerings expand. Selected new Toyota models have internet connectivity via an in-vehicle communication device called a Data Communication Module (DCM). This supports the functionality of safety and security features, and additional features still under development.

All connected vehicle data is protected in accordance with Toyota Australia's data privacy policy and Australian law. See [p. 18](#) for more information. See our website for more information on [Connected Services](#) and [Safety Features](#).

Connected and automated technologies can help reshape mobility, but they also come with risks, including that current technologies could be displaced by new technologies and competitors, or that our technologies could be incompatible with new policies and infrastructure. These variables are outside Toyota Australia's direct control. To mitigate these risks, we collaborate with governments, academia and industry to encourage development of compatible technologies and policies, and demonstrate their benefits. We also advocate for investment in data transmission infrastructure that enables Toyota vehicles to communicate with each other and with other road infrastructure such as traffic lights.

Toyota connected and automated features

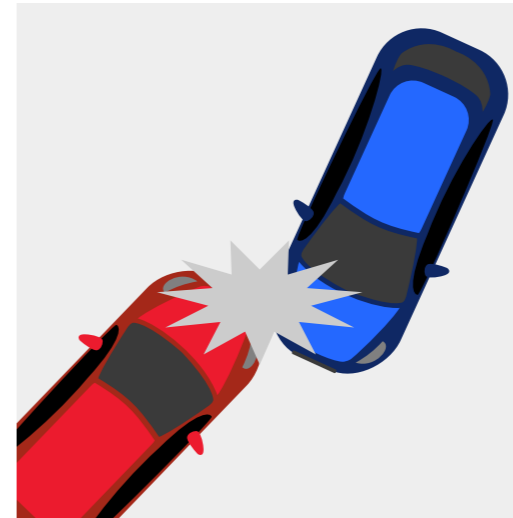

Automatic Collision Notification



SOS Emergency Call button in vehicle

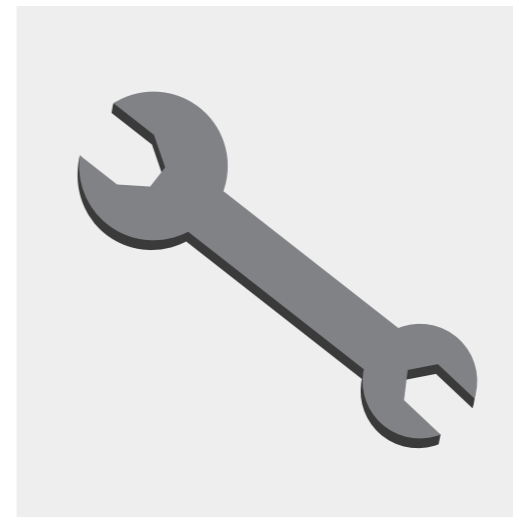

Toyota Emergency Assistance

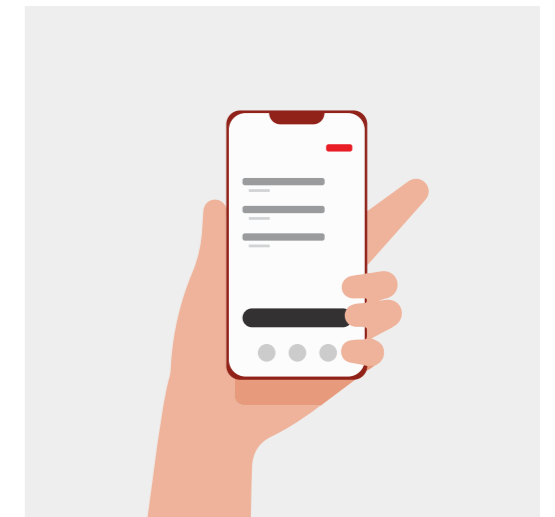

Driving insights through the myToyota Connect app

Data privacy and security

Connected and automated vehicles rely on high volumes of data being transferred across networks. It is imperative that the data is secure and the digital infrastructure is resilient to cyber attacks that could have a significant negative impact on our company and our customers, and erode trust in our brand.

These risks are not exclusive to connected and automated vehicles. Toyota puts our customers first by ensuring the safety and security of their personal information, to ensure that their experience with Toyota remains a positive one.

In FY22, there were 12 reports of actual and alleged data breaches. Toyota Australia's Privacy Officer investigated all reports and identified no reportable incidents. All confirmed breaches were quickly contained, and Toyota Australia notified affected individuals of our actions to contain and remediate the incidents. We take all breaches seriously, even when not reportable, and strengthen our approach to cyber security with every investigation.

Our approach to data privacy and security

Privacy Policy

The policy outlines our approach to customer privacy, in accordance with Australian Privacy Principles. We comply with the Notifiable Data Breaches Scheme under the *Australian Privacy Act 1998* (Cth.) to investigate, manage and notify Australian regulators if a data breach occurs.

Information Security Management System Policy

This system is based on ISO/IEC 27001:2013 Information Security Management. It covers both third-party information held by Toyota Australia, and Toyota Australia information held or managed by others.

Information Security Management Committee

The Committee reports directly to the Executive Leadership Team, manages our information management framework and regularly reviews the current systems and processes to identify opportunities for improvement

Toyota Australia is currently in the third year of our cyber security uplift program, Thunderbird. The program aims to improve our security maturity to level three National Institute of Standards and Technology (NIST) rating, to enable us to protect all our data and our customers' privacy better than ever before. Thunderbird will reduce our vulnerability to cyber attacks by using a combination of firewalls, intrusion prevention and Cloud anti-virus protections as our first line of defence. This initiative is supported by our newly introduced cyber security testing, training and awareness programs for Toyota employees and 24-hour cyber event logging, which will reinforce our ability to respond to threats.

Toyota Australia's corporate position on data privacy

As a customer-centric organisation, we recognise the importance of protecting our customers' personal information. We are committed to establishing trust in responsible data governance, while enhancing products, services and experiences for Toyota and Lexus customers. There are significant benefits to new technologies that will enable connected mobility, but we need to take a precautionary approach when introducing them to ensure our customers' privacy rights are respected.

Accordingly, our corporate position in relation to personal information is not only to comply with current and emerging Australian privacy law requirements but to work towards establishing a sustainable and superior data protection program that reflects global standards. In striving for this goal, we are committed to:

- being transparent with customers about how their information is collected and the purposes for which it is used (even where that use is on an aggregated or de-identified basis)
- offering customers the ability to control the collection of their information by, for example, providing them with the ability to opt in or opt out of any paid connected service
- thoroughly considering our customers' privacy when developing new products and services.

On a more general level, Toyota Australia's Privacy Policy sets out our approach to the collection, use and disclosure of our customers' information, in accordance with Australian Privacy Principles. This includes a requirement to obtain customers' consent for any sensitive information collected.

Our framework to investigate, manage and notify Australian regulators of any data breaches supports our compliance with the Notifiable Data Breaches Scheme under the *Privacy Act (1988)* (Cth). Where practicable, we align our practices with Europe's legal standard for General Data Protection Regulation, which is widely considered to be the 'gold standard' for data protection.

Strategic partnerships

Mobility innovation and transformation cannot be realised by one company. We work with industry partners, suppliers, governments and academia to achieve more together than we could separately.

The Toyota dealer network is one of our most important partners, and the success of our business is closely tied to theirs. We work with dealers on a range of initiatives including new mobility services and operational improvements. See [p. 30](#) for more information.

Collaboration in action

Technology

We work with industry partners, academia and government research organisations to share knowledge and technical expertise on C-ITS.

Infrastructure

Electric charging, connected and automated driving infrastructure across our vast and diverse country poses a challenge that will depend on public-private partnerships, cross-sector expertise and combined investment.

Policy

Our External Affairs team communicates with governments to provide industry perspectives on mobility policy directions. The FCAI facilitates a platform for collaborative industry advocacy.

Education

The Toyota Hydrogen Centre showcases hydrogen technology and practical applications to government and industry groups, encouraging collaboration on implementing policy and infrastructure to enable this technology across Australia.

Advocacy and regulatory engagement

Regulatory compliance is critical to preserve our reputation as a responsible market leader and to ensure the resilience of our business. The future of ICE vehicle sales will be impacted by increasing electrification, infrastructure and related regulations. In particular, the evolving regulatory landscape on vehicle emissions poses a significant change point.

We provide an industry voice to government, advocating for policy and investment that will best support the decarbonisation and modernisation of the transport sector while preserving customer choice. In FY22, we focused particularly on hydrogen and connected technology development. We believe that industry expertise and perspectives support governments to prioritise investments for viable initiatives with the greatest potential for positive impact.

Our ongoing engagement with government both through our External Affairs department and associations including FCAI, Australian Industry Group and Committee for Economic Development of Australia (CEDA) enables us to gain a better appreciation of the complexities associated with the changing regulatory environment, so we can adjust our strategies to meet our obligations.

Toyota Australia does not make political contributions. In FY22, Toyota Australia received \$1,513,600 in government funding through the Australian Renewable Energy Agency to complete the Hydrogen Centre project.

More information on how we engage with government is on [p. 8](#).

CASE STUDY

Hydrogen – fuel of the future

Decarbonising heavy and long-distance transport is a challenge that cannot be met with electric powertrains alone, due to sustained and intense energy needs. This is why we are investing in developing hydrogen technology. We showcase hydrogen technology at the Toyota Hydrogen Centre, demonstrating its potential to government stakeholders. We also contribute our expertise to policy discussions, to drive our vision of a hydrogen future and advocate for infrastructure investment across Australia to support this technology. Read more about our hydrogen projects on [p. 21](#).



Toyota demonstrated the broad potential for hydrogen fuel cell technology powering the Marvel Stadium sign



RMIT Engineering Students visit to the Hydrogen Centre

Reducing environmental impacts



Our ambition

Through their life cycle, fossil-fuel powered vehicles create carbon emissions and pollution, or other forms of negative environmental impact. We work to mitigate the negative environmental impacts of our vehicle range by introducing low and zero emissions vehicles.

Our mission of creating happiness for all is a key driver of our ambition to reduce or eliminate, as far as practically possible, negative impacts associated with our products and to drive Australia towards more sustainable mobility.

Lower carbon mobility

Australians are concerned about climate change and sustainability, and expect companies to do more to achieve carbon neutrality by 2050. Toyota has more cars on Australian roads than any other brand and the emissions from these vehicles has a significant climate impact.

Globally, Toyota aims to achieve carbon neutrality by 2050 through an inclusive, multi-technology approach that aims to leave no one behind. This approach is guided by our mid-term business plan. We are working towards expanding our range of low and zero emission vehicle options to suit our customers' individual needs.

Toyota globally are focused on improving vehicle performance and environmental impact throughout the lifecycle; from minerals extracted for manufacture, to end-of-life processes such as battery recycling.

The next phase of electrification

Consumer interest and awareness for lower-emission vehicles is growing. Over the past 20 years, Toyota has created a pathway for improve their vehicles to lower emissions through weight reduction and improved engine performance. Our strategy has focused on mainstreaming hybrid technology as an affordable and accessible electrified option, and hydrogen fuel cell electric vehicles (FCEVs) along with battery electric vehicles.

TMC is expanding and diversifying the Toyota and Lexus electrified vehicle line-up to 70 models by 2025 globally. Electrified vehicles encompass HEVs, FCEVs, BEVs and plug-in hybrid electric vehicles (PHEVs).

Toyota Australia will make more of these electrified models available in Australia over the coming years. By 2030, Toyota will globally spend in excess of US\$30 billion on research and development, with half of this investment going to BEVs and battery technology.

TMC's holistic electrification strategy will go beyond just expanding the range of electrified vehicles. We continue to develop our systems for electric battery management, from supply to servicing and recycling at their end of life. Our electric charging strategy remains in early development and ultimately aims to provide charging solutions that support our dealers, fleet customers, individual customer home charging, and publicly accessible infrastructure.

To achieve carbon neutrality, electrification must accelerate for all global automotive companies. This is why we share our electrification expertise with our strategic industry partners. TMC and Subaru jointly developed the Toyota bZ4X, leveraging each companies' unique strengths to create the best product. Toyota's hybrid electric powertrain technologies enable Subaru to develop their own electrified line-up and advance the low carbon vehicle market for all.



Akio Toyoda introduces 16 new BEVs at global press conference

Hybrids obtain energy from petroleum but use an electrical system to improve fuel efficiency.

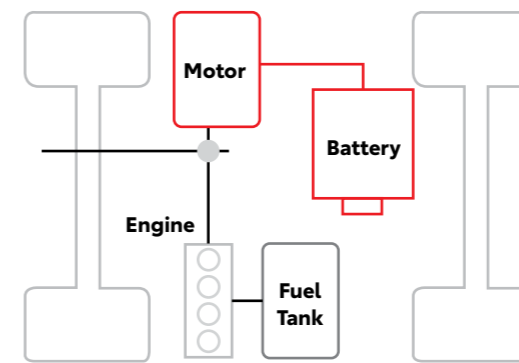

Plug-in Hybrid Electric Vehicles store energy from the electric power grid and can drive partly using electricity and partly using petroleum.

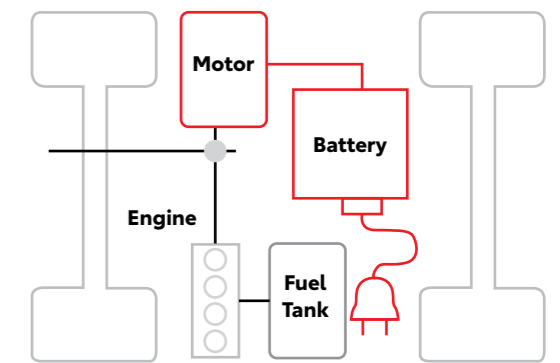

Battery Electric Vehicle have large battery packs to store more energy from the electric power grid for longer range.

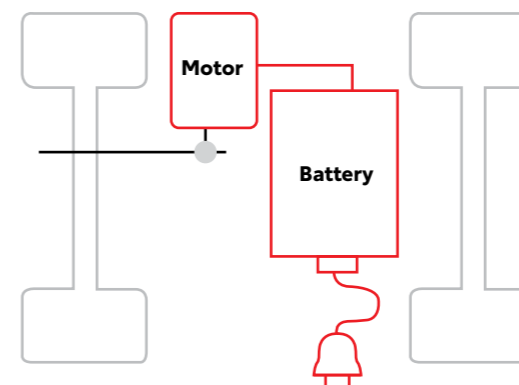

Fuel Cell Electric Vehicle refuel with hydrogen and use a fuel cell to produce electricity to propel the vehicle.

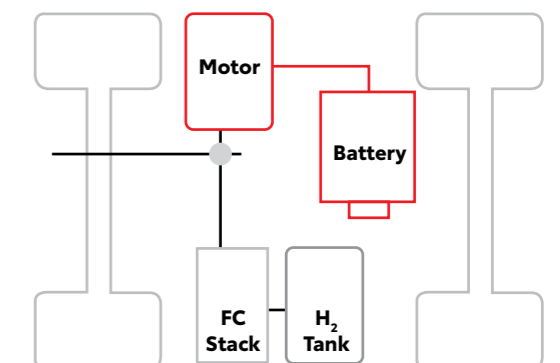

CASE STUDY

Introducing the UX 300e and bZ4X SUV

In November 2021 Lexus launched its first BEV, the UX 300e. The marketing campaign for the UX 300e was certified carbon neutral by Climate Active. Customers reacted positively to the UX 300e, with 72 units sold in the first four months it was available in the market, and a further 143 units ordered, demonstrating Australians' demand for diversified electrified powertrains. Our sales target was 78 vehicles, which we were unable to meet due to short-term supply shortages. At the end of FY22, customer orders for 71 vehicles were awaiting fulfillment. Beyond overcoming supply disruptions, Toyota Australia plans to increase our sales of BEVs by providing early-adopter customers with a risk- and hassle-free BEV ecosystem, from servicing to charging and mobility services.

In FY23 the Toyota brand will release the first of TMC's global **Beyond Zero** (bZ) BEV vehicle line-up in Australia, the bZ4X SUV. Globally, TMC plans to roll out 30 new BEVs by 2030, resulting in a comprehensive line-up of electric passenger-cars, SUVs and commercial vehicles.



Hybrid electric vehicles

Toyota's electrification strategy prioritises hybrid to drive the fastest cumulative emissions reduction, due to their accessibility to customers. Toyota and Lexus HEVs on average emit 30% less carbon than the equivalent ICE vehicles. We continue our efforts to:

- Raise HEV awareness amongst our dealers, so they can provide our customers with the best information. We achieve this through conferences, training and regular communication of Toyota Australia's 2030 Direction
- Leverage our brand power and marketing to drive broader awareness and acceptance of hybrids across Australian society.

For more information on HEVs, see [our website](#).

Hydrogen development for a decarbonised future

Zero emissions hydrogen technology is critical to Toyota Australia's vision of a carbon neutral Australia, and we dedicate significant financial investment and executive attention to its development. We collaborate with our peers, other industry, government and academia to lead the hydrogen movement in Australia, where our New Business Solutions General Manager serves on the Board of Australian Hydrogen Council. Through the Council and other committees including the Policy Advisory Committee and Infrastructure Committee and working groups, Toyota Australia fosters industry, government and academic collaboration to drive

Toyota and Lexus HEV sales

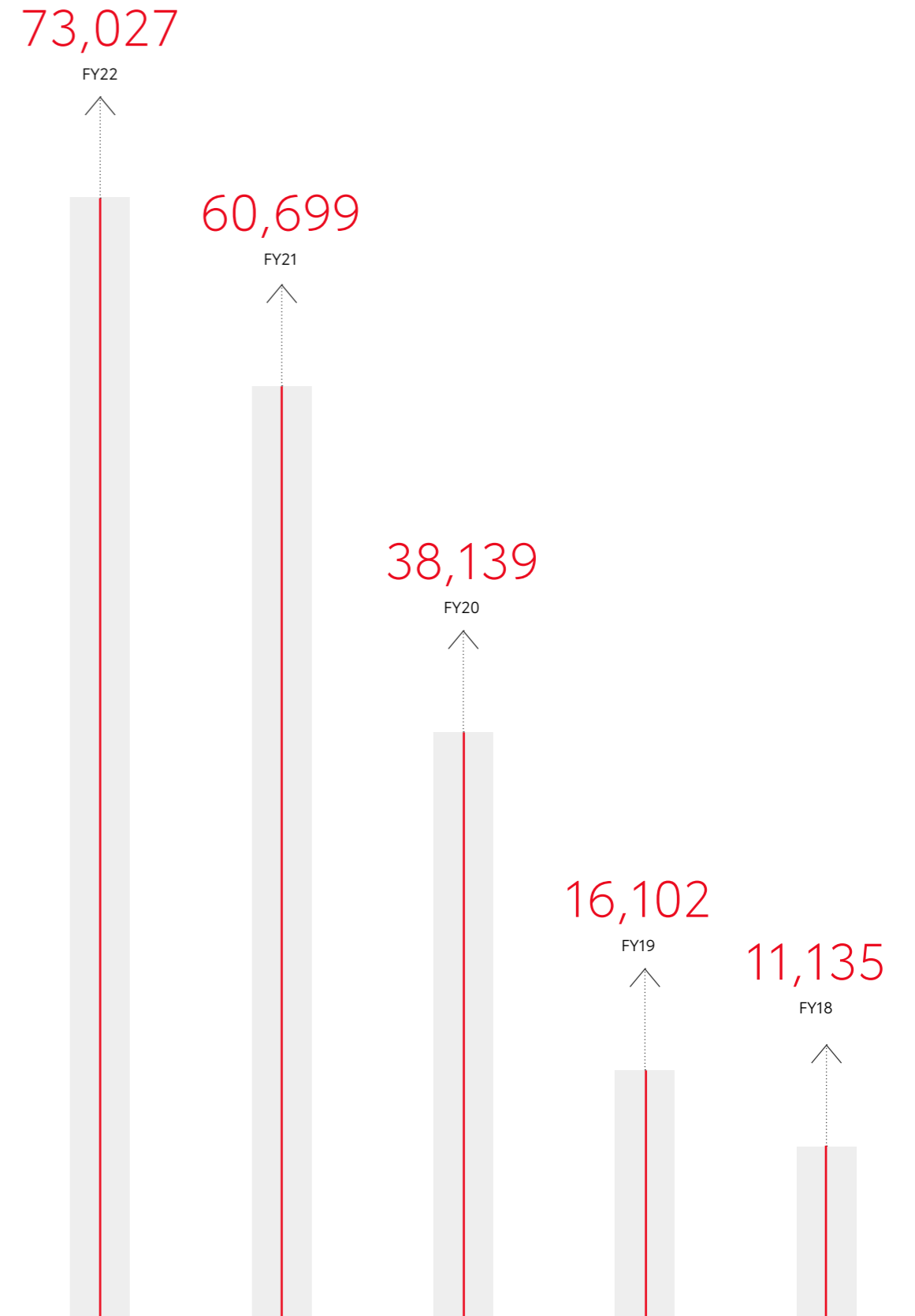

hydrogen education, technology and infrastructure. See [p. 19](#) for more on our approach to hydrogen advocacy.

In FY22 we continued to provide demonstrations of the Mirai FCEV to businesses and governments. In addition to those Mirai leased for TMCA's own fleet, the CSIRO was Australia's first organisation to lease the Mirai in early FY22 for research at its hydrogen refuelling test facility. Early-adopter businesses, such as Red Energy, added Mirai vehicles to their fleets, to explore and demonstrate hydrogen's viability and real-world application.

The Toyota Hydrogen Centre is the heart of our hydrogen strategy.

- Capable of hydrogen production up to 80 kg per day, the centre produced approximately 140kg hydrogen per month from December 2021 to March 2022
- Commercial hydrogen refuelling
- Mirai vehicles leased in FY22: 17
- Mirai servicing facilities
- Educational environment for government, academia and industry to showcase Mirai FCEVs
- The electrolyser uses town water for the reverse osmosis and de-ionisation processes to create hydrogen. Designed to discharge excess water into the sewer at a maximum of 25L per kg of hydrogen, the centre discharged approximately 9 L per kg per month from December 2021 to March 2022, with a maximum discharge of just over 30 L per kg in February 2022.

The Mirai value chain leverages our One Toyota Network partners.

Toyota Australia / ONE Toyota Partner

Mirai Value Chain



For more information, see our [website](#).

From the hybrid and electric Toyota and Lexus vehicles sold in FY22, the approximate average emissions per km driven across all vehicles sold was reduced by 15.1g compared to a scenario where customers bought an equivalent ICE vehicles instead of a lower carbon vehicle.

Average carbon avoided due to current HEV and BEV sales

	Average CO ₂ g/km avoided if HEV and/or BEV were sold as equivalent ICE vehicles models*	Average CO ₂ g/km for all cars sold in FY22, including HEV and BEV models	Average CO ₂ g/km avoided due to current HEV and/or BEV sales
Toyota	188.1	173.3	14.8
Lexus	183.1	158.6	24.5
Combined	187.9	172.8	15.1

Data assumptions and boundaries:

- * HEV and BEV sales volume was rolled into the closest ICE vehicles variant
- * Zero and low emissions Mirai, Prius and Prius V sales have been excluded from this calculation as there is no ICE vehicles equivalent
- * Where models had powertrain improvements to reduce emissions during the reporting period, this analysis has used the higher CO₂g/km figure.



CSIRO Chief Executive, Dr Larry Marshall test driving the all-new Mirai at the Toyota Autodrome

Vehicle lifecycle

There is a growing expectation that companies' responsibility for the products they sell extends to the full value chain and lifecycle.

Reducing the lifecycle environmental impacts and carbon footprint of Toyota products is part of the Toyota Environmental Challenge 2050 goal

for achieving carbon neutrality, and our broader ambition to develop ever-better vehicles.

The graphic below sets out environmental impacts throughout the Toyota Australia value chain, and carbon neutral target years for each stage. See **p. 28** for more information on how Toyota Australia manages some of these impacts

through engagement with our direct suppliers.

Toyota Australia's Sustainability Mid-term Business Plan has laid out a phased approach for carbon neutrality across our products' lifecycles, consistent with our sustainability strategy. In the short term, we are prioritising immediate carbon reduction over our own

operations, where we can exert the most control. In the longer term we are focused on emissions of our partners and products and services.

Tailpipe emissions and embedded emissions in our supply chain represent the greatest portion of our vehicles' carbon footprint. Improving our performance in these areas will support improved

environmental performance for our partners, customers and the broader economy. We continue to work towards carbon neutrality in these areas by collaborating with TMC on better vehicle design and more efficient engines. For more information on how we manage supply chain risks, see **p. 28**.

Potential environmental impacts in Toyota Australia's vehicle value chain

VEHICLE VALUE CHAIN

Raw materials for vehicle engines, powertrains, bodies and interiors (overseen by TMC)

Vehicle and parts manufacturing and supply by TMC and other suppliers

Toyota Australia operations, marketing and logistics for vehicle distribution to dealer network, Toyota Australia fleet and business travel

Dealer network operations

Vehicle use by customers

Vehicle end-of-life, including disposal, reuse and recycling through One Toyota or third parties

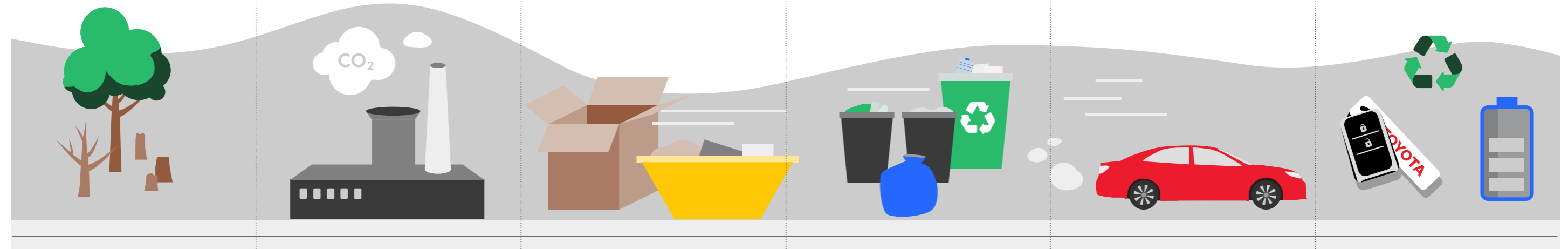

POTENTIAL ENVIRONMENTAL IMPACTS

Environmental damage from materials extraction and/or processing, e.g.

- leather production, associated with deforestation
- impacts of lithium mining

Operational emissions

Dependence on virgin materials

Manufacturing waste and pollution

Operational emissions

General operational waste

Packaging waste from Toyota Parts Centres

Pollution and emissions from operations and logistics

General operational waste

Operational emissions

Tailpipe emissions, pollution, particulate matter, oils, refrigerants, residual fuel and coolant

Emissions from HEV and BEV charging

Vehicle disposal reinforces dependence on virgin materials

Battery waste, including toxic materials

Operational emissions

CASE STUDY

Tailpipe emissions

Our most significant negative environmental impacts come from tailpipe emissions from Toyota vehicles on the road. It is challenging to accurately measure our Scope 3 emissions from individual vehicle use, but we recognise that due to our market share our vehicles contribute a notable percentage of Australia’s total emissions.

Our business strategy is focused on providing our customers with a range of vehicle options to suit their individual, diverse lifestyles and preferences in line with our vision of providing mobility for all. We continue to invest in and expand electrified and hydrogen offerings to reduce our environmental impact.

Toyota will continue to work with government and welcome long term policy certainty that comes with mandated CO2 targets.

Australia currently has the lowest quality fuel in the Organisation for Economic Co-operation (OECD). Toyota Australia and the FCAI advocate for improving national fuel standards to be consistent with the World Wide Fuels Charter. Better fuel for Australians would enable more advanced ICE powertrains and reduce emissions and pollution. Toyota Australia also supports the FCAI Voluntary CO2 Emissions Standard, which tracks brands’ average vehicle emissions against the Standard’s stretch target.

Efficient product design to minimise environmental harm

During product development, TMC’s Eco-Vehicle Assessment System (Eco-VAS) guides how TMC designs fuel-efficient engines that emit fewer tailpipe emissions, air pollutants and particulate matter. The Eco-VAS process includes vehicle life cycle assessments (LCAs), which assess products’ environmental impacts throughout their value chain.

The carbon and environmental value chain impacts between our ICE vehicles and lower carbon models vary depending on materials, manufacturing and disposal processes, as well as tailpipe emissions.

Toyota vehicle average fuel consumption

Weighted average fuel economy of light passenger and commercial fleet sales FY22

Average fuel consumption (L/100km)*

Toyota sales	Lexus sales
6.9	6.8

Manufacturing

Vehicles manufacturing relies heavily on a broad range of natural resources, which contributes to resource depletion and waste when materials cannot be reused. Manufacturing is also carbon intensive, including embedded emissions in components.

While electrified vehicles have a key role to play in accelerating the decarbonisation of the transport sector, batteries rely on raw materials such as lithium that can cause environmental damage. As more of these minerals are needed to meet market demand, these impacts, together with the risk of supply disruption, pose challenges for future mobility electrification. We are responding to the supply chain risk by reinforcing strong supplier partnerships.

In October 2021, Toyota Motor Corporation and BHP affiliates signed a Memorandum of Understanding to collaborate on improving the sustainability of the Japanese battery

supply chain. This includes lowering carbon emissions in battery value chains and identifying ways to implement standards for end-to-end raw materials traceability, ethical sourcing and human rights reporting.

See **p. 28** for more information on supply chain risks.

TMC and Toyota Australia are taking steps to reclaim and reuse more materials where possible, to reduce the volume of natural resources used in Toyota products and batteries. Our programs to reduce waste throughout the vehicle lifecycle include:

Australia

Hybrid Battery Recycling Program

FY22:
1,954 hybrid batteries recycled

FY21:
1,542 hybrid batteries recycled

Electric vehicle conversions and refurbishments

TPC recycling

Global

Toyota Global 100 Dismantlers Project

Toyota Global Car-to-Car Recycle Project

From 2022 to 2025, our priority in relation to battery recycling is to maximise our HEV battery recycling

rate. In the long term, we aim to reduce the amount of waste generated by improving rates of reuse, repurposing and recycling.

Toyota Australia is currently developing a strategy to accelerate local HEV and BEV battery recycling capabilities, and to collaborate on a pilot battery reuse study with external research groups. We incentivise customers to return their used hybrid vehicle batteries for recycling by offering two rebate options through the Toyota dealer network:

- A \$100 cash rebate when customers return a hybrid vehicle battery
- A discount of \$500 off the purchase of a replacement battery

In FY22, Toyota Australia recycled 1,954 hybrid batteries from both Toyota and Lexus models. These batteries are recycled overseas on our behalf.

Operational environmental impacts

While the majority of Toyota Australia’s emissions come from vehicle use and other activities throughout our value chain, our operations also generate emissions, waste and other adverse impacts that require proactive impact mitigation management. Our Kaizen philosophy of continuous improvement guides our efforts to

*Average fuel consumption (L/100km) weighted by FY22 sale volume of Toyota and Lexus light duty vehicle models. Average does not include heavy vehicles. Fuel consumption values by model used in this calculation are drawn from fuel consumption data submitted to the Australian government for certification and labelling.

actively identify and act on areas where we can do better.

The Toyota Australia Environmental Policy underpins our vision to be an environmental leader, which operates a sustainable business in harmony with nature. We are committed to:

- Zero non-compliances and complaints
- Minimisation of environmental risks
- Protecting and conserving biodiversity and ecosystems
- Continuous improvement in line with the Toyota Environmental Challenge 2050.



Energy

Our first step in working towards carbon neutrality is decarbonising Toyota Australia’s operations. We are significantly expanding our solar electricity generation capacity across our facilities, with new systems installed in FY22 and more planned for FY23. In FY22 we were proud to commence installation of an additional 7,883 solar panels at our Altona Toyota Parts Centre (TPC) warehouse to be commissioned in FY23. Once commissioned, this 2.5MW system will produce enough electricity to power the equivalent of 500 houses. Using solar energy across our facilities reduced our emissions by approximately 1762 tonnes CO2e over FY22.

The Sydney Toyota Parts Centre (TPC) is now powered by 100% renewable energy.

Logistics

Toyota transports vehicles to dealers across our vast country. The haulage vehicles are diesel-powered and represent a significant source of Toyota Australia’s operational emissions. The Toyota Production System optimises our logistics by determining the most direct transport routes and ensuring efficient coordination between TMC, Toyota Australia and Toyota dealers. We engage a third-party logistics company to manage and execute our logistics, including ownership and maintenance of heavy vehicles, to make sure they are as efficient as possible.

FY22 Solar generation in kWh

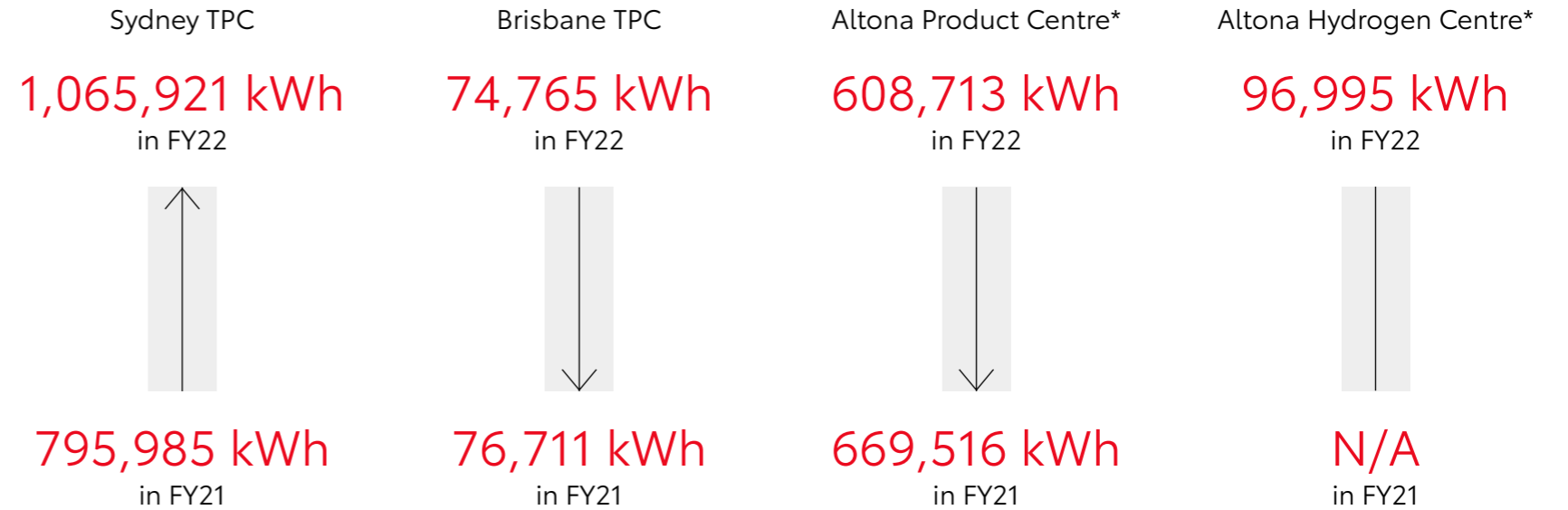

*Note: In the 2021 Sustainability Report, we reported solar generation for the Altona Product Centre as the Altona Hydrogen Centre. This has been corrected in this report and correct data is provided in the table above.

We continue to measure our scope 1, 2 and 3 greenhouse gas emissions.

Toyota Australia’s emissions

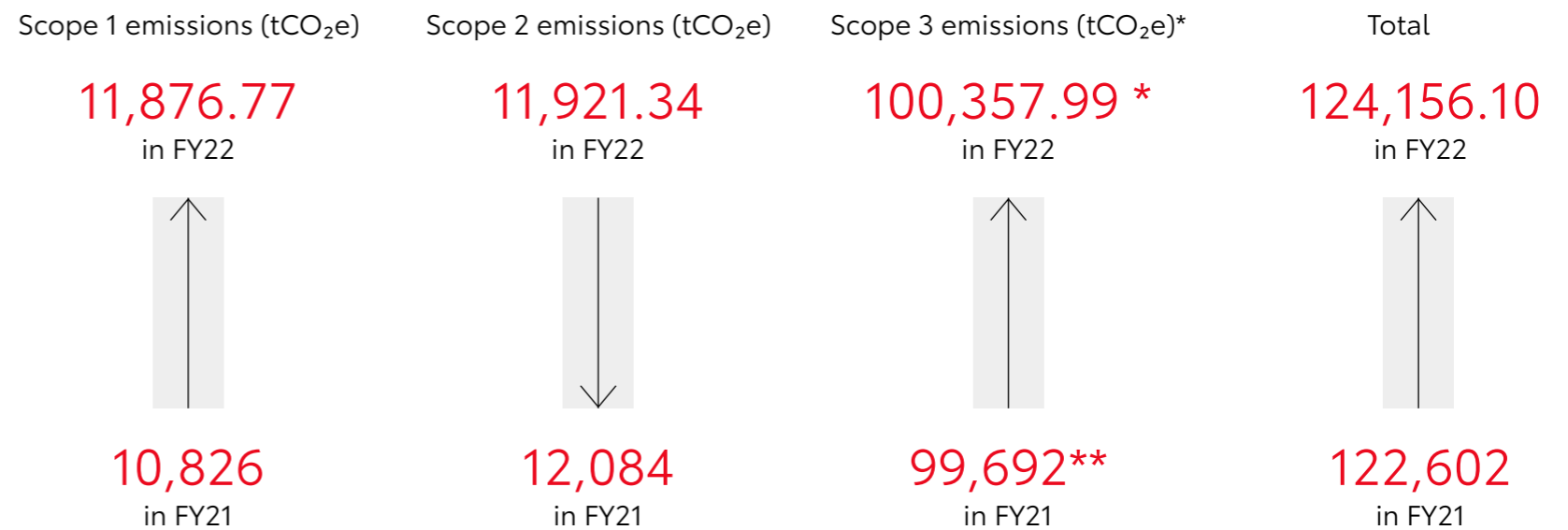

*Scope 3 emissions have increased as the dataset has become more accurate and complete, in particular incorporating a more detailed breakdown of marketing and IT activity sub-categories

**Standards, methodologies and assumptions used in the above calculations

We support our dealerships to increase their solar generation capacity by facilitating solar panel group buys to reduce the costs for dealers. For more information, see [p. 30](#).

We aim to reduce our logistics emissions by 2.5% compared to the previous year. Unfortunately, in FY20 and FY21, we did not meet this goal. The data for FY22 is not available at the time of writing. We are working to improve communication between Toyota Australia and our third-party provider to better monitor our logistics' environmental performance.

Environmental management system

The Toyota Environmental Management System (TEMS) governs how we manage and reduce environmental impacts at our Port Melbourne headquarters and Altona TPC operations, including the All Time Buy centre, which stores spare parts for older Toyota models. TEMS is certified against the ISO14001 standard for environmental management at these sites, and we are currently seeking certification at additional facilities.

We believe our employees are one of our most valuable sources of new ideas to reduce environmental impacts at the facilities where they work. Toyota Australia empowers our employees by developing their awareness of potential environmental risks and the actions they should take whenever they suspect a problem.

In FY22, our Toyota Parts Centres (TPC) facilities rolled out the Treasure Hunt Program, which invites our employees to suggest process improvements to achieve on-site savings for utilities and resources. We reward contributors with the opportunity to win prizes designed to help reduce their own waste at home. This year we provided Swag Bag Starter Packs: an eco-friendly food storage solution which extends fruit and vegetable freshness by up to two weeks to minimise food waste.

In March 2022, we had two instances of environmental regulatory non-compliance related to one event at our Altona facility. See [p. 12](#) for more information.

Waste reduction

The majority of Toyota Australia's operational waste originates at TPCs and comprises mainly product packaging. As part of our Environment Kaizen, our TPCs continue to trial and implement waste-reduction strategies and initiatives.

CASE STUDY

Recyclable timberless packaging trial

Our TPCs are currently developing different types of cardboard-based pallets to contribute to our goal of 100% recyclable packaging at all our branches. Traditional pallets used to ship orders to our customers across Australia are made of timber, which is typically discarded to rubbish. We estimate transitioning to fully recyclable pallets could reduce the amount of timber heading to landfill by up to one tonne every day.



Strong economy and thriving communities



Our ambition

Toyota Australia’s mission to create happiness for all extends beyond our employees and our customers. We strive to leave a positive mark on the Australian economy and society by supporting the economic success of the businesses and communities that rely on our vehicles, and by contributing meaningfully to the capabilities and resilience of Australian people. Our financial success enables us to invest in our team and support our communities. Australian businesses, small and large, contribute to thriving communities and a healthy economy. By supporting our dealers’ and suppliers’ success, Toyota Australia helps to generate employment and build resilient communities beyond our own operations.

Indirect social and economic impacts

Corporate and fleet customers

Toyota vehicles keep our corporate and fleet customers on the road. Fleet customers represent almost half of Toyota Australia vehicle sales, and include businesses of all sizes, not-for-profits and government organisations. We serve these customers through specialised Toyota fleet dealers, who work to understand their unique mobility needs so that we can provide the most suitable products and services. These needs may include:

- specific vehicle types for different areas of operation
- lower-emissions vehicles to reduce their environmental footprint and meet their sustainability goals
- streamlined services and administration to reduce costs
- connected technologies to monitor their drivers’ safety and improve efficiency.

FY22 Toyota Australia fleet sales

Corporate

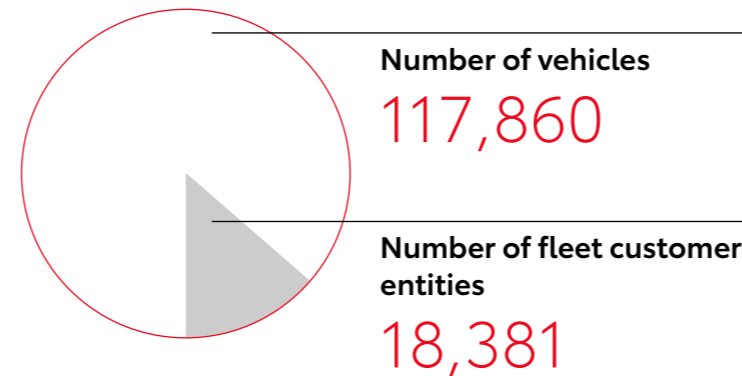

Other, including rental and not-for-profit

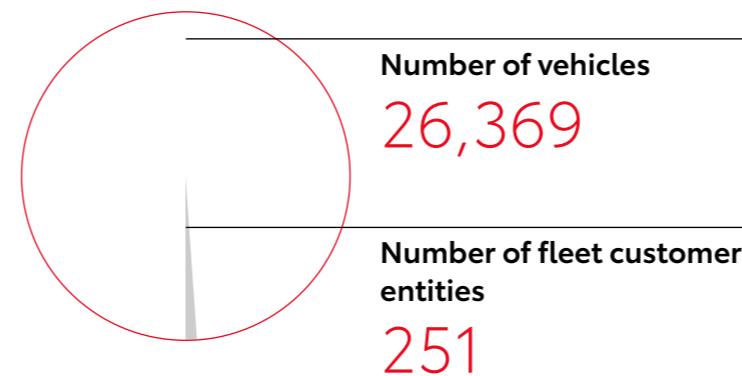

Government

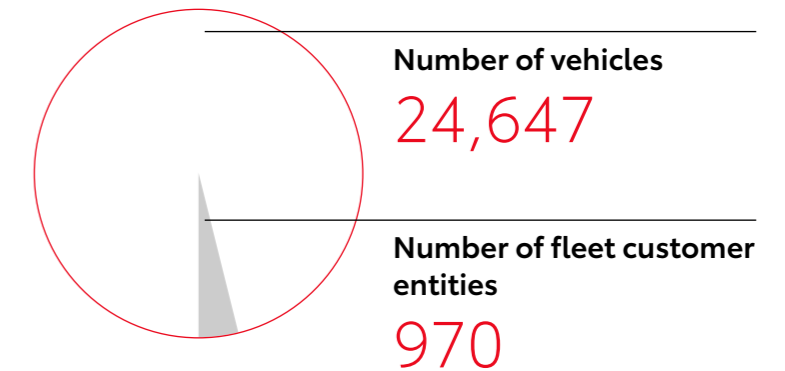

Total sales

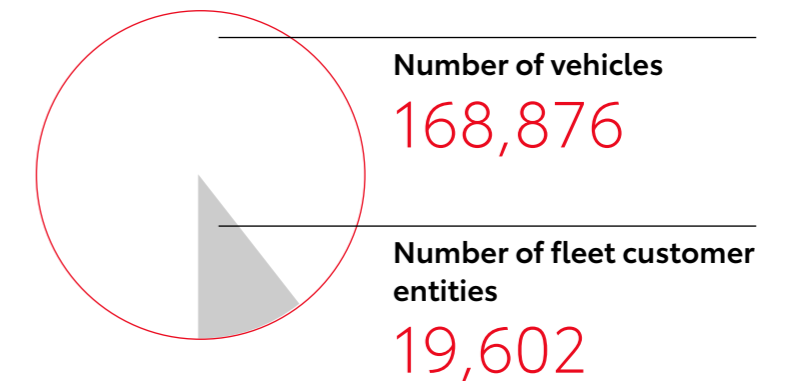

Suppliers

As one of Australia’s largest companies, we both depend on, and create financial value for the suppliers that we work with. Our ability to provide our customers with the best Toyota experience depends on the businesses that supply the products and services we rely on. Our long-term partnerships with these suppliers mean we can contribute to strengthening their businesses by improving their capabilities, capacity and internal processes through collaboration.

When selecting suppliers, we prioritise building long-term relationships with businesses that are aligned with our vision, values and strategic objectives. As Toyota Australia evolves from an automotive company to a mobility provider, the parts and accessories that we need for our vehicles are changing, becoming more complex in nature and dependent on technology. We need to identify both existing and new suppliers capable of providing products or services for our future needs. We manage this risk to our suppliers through ongoing communication about our changing needs, to give them the opportunity to adapt their business plans and uplift their capability accordingly.

The below information refers to third party suppliers of parts, accessories and services. This does not include the manufactured vehicles or parts we source through TMC or other Toyota affiliates.

FY22 supplier spend

	Number of suppliers	Value of spend
Service parts and accessories	72	\$0.333 billion
Other goods and services	1,174	\$0.783 billion
Total suppliers	1,246	\$1.116 billion
% suppliers based in Australia		93.5%
Spend with Australian suppliers		\$1.088 billion (97.5% of total spend)
Total new suppliers in FY22		203

Local suppliers by location

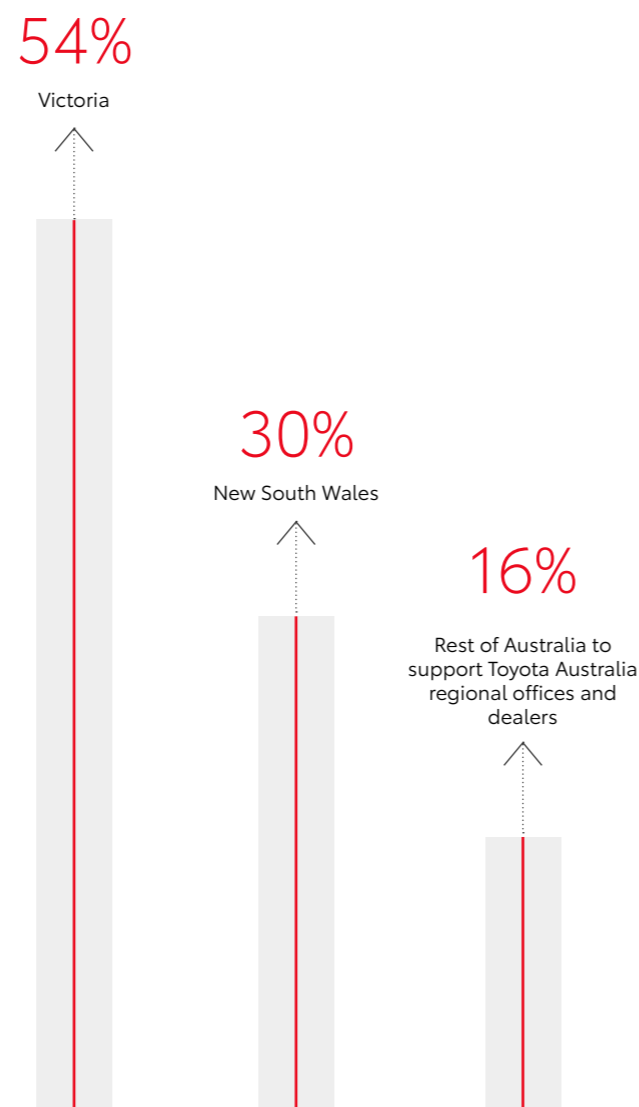

Supply chain risk

Supply chain risk

FY22 was characterised by intensifying supply chain disruptions due to the ongoing impacts from the COVID-19 pandemic, extreme weather events in Australia, and the war in Ukraine. The supply shortages and delays have impacted Toyota Australia’s ability to deliver our products to our customers in the usual timely fashion, creating longer wait times for new vehicle deliveries. This can be disruptive to our customers’ lives and reduce their satisfaction with their Toyota experience. We provide information on delivery wait times and vehicle supply problems on our [website](#).

While Toyota Australia cannot directly influence these disruptions, we respond by clearly communicating supply updates and expected delivery times with both our employees and customers. We believe a transparent approach to communicating delays is the best way to maintain trust in our brand. See [p. 13](#) for more information on how we communicate disruptions to our customers.

Two-way communication about our suppliers’ ability to fulfil orders and Toyota Australia’s order volume expectations means we can support our suppliers’ business continuity while also implementing long-term capacity-building solutions and flexibility into our supply chains. Toyota Australia Contract Managers form a bridge between our business and our suppliers, and support

suppliers to meet their performance reporting obligations. When these managers meet with our suppliers, they represent Toyota Australia’s interests, and when relaying information to Toyota Australia they advocate for our suppliers’ needs.

Environmental risks

Our suppliers, and their own network of suppliers, are a significant part of our value chain. Our Supplier Minimum Standards require suppliers to take every effort to comply with applicable environmental regulations, and aim for zero emissions in their business operations. While there have been no instances of negative environmental impacts reported within Toyota Australia’s supply chain during FY22, we know there remains potential for harm, so we adopt a proactive management approach to mitigate and manage incidents should they arise. See [p. 23](#) for more information on environmental risks across our vehicles’ lifecycle.

While Toyota Australia has limited control and oversight of environmental impacts in our supply chain, we expect the suppliers we engage with to have systems in place to reduce these risks. We screen selected key and new suppliers for their approach to environmental management through the Toyota Australia Supplier Evaluation System. Supplier assessments include considerations for capabilities and performance across delivery, cost, quality, and safety and some environmental indicators. We require suppliers to

report on their performance across these areas on a quarterly basis. Where standards are not met, Toyota Australia works with the supplier to understand the reasons for this, and develop remedial or mitigating actions. Toyota Australia does not currently undertake due diligence around suppliers' processes for environmental management, but this will be considered as part of our updated sustainability guidelines in FY23.

Toyota Australia plans to establish a more robust screening procedure to assess new suppliers on their sustainability management and performance, building on the modern slavery considerations already embedded during tender processes. As part of our supplier engagement, we will also introduce sustainability performance as a priority, and support them to improve their practices over the course of their contracts with us.

Modern slavery risks

Modern slavery risks are particularly high in raw materials extraction and manufacturing industries, where it can be challenging to establish full transparency and traceability. We do not have direct control over our suppliers' operations; however, guided by our value of respect for people, we manage these risks by implementing a robust procurement framework, and are committed to eliminating modern slavery practices if found.

When sourcing new suppliers, we ensure that they adhere to our Supplier Minimum Standards and further analyse areas where more information is required to satisfy them.

Toyota Australia's Supplier Minimum Standards stipulate that we expect suppliers to adhere to:

- Free and voluntary employment, free from any forced or bonded labour or deceptive recruitment practices
- No child labour, including the commitment to eliminate child labour from their supply chains
- Responsible material procurement, including not procuring conflict minerals
- Respect and dignity to all workers
- Freedom of association
- Legal wages and employment benefits
- Workplace safety
- Notification to Toyota Australia when an instance of modern slavery is identified in their operations or supply chain, and the remediation process undertaken.

Suppliers are also expected to comply with TMC's Human Rights Policy.

We continue to monitor our supply chain for modern slavery risks through supplier assessments and

questionnaires, which are aligned to our Supplier Minimum Standards. Our Modern Slavery Working Group consists of representatives from across Toyota Australia's Divisions who maintain momentum in their Divisions in relation to allocated responsibilities to ensure our modern slavery due diligence is progressing as planned.

We have established grievance mechanisms for modern slavery concerns. Our principles for remediation are embedded in our Modern Slavery Policy and aim to improve and repatriate conditions for the victims, whenever detected. The ultimate goal is to stop instances before they have had the chance to begin, by ensuring proactive measures such as ethical sourcing standards and practices are in place throughout the supply chain. Modern slavery requirements are already incorporated into our Supplier Minimum Standards. We plan to extend these in FY23 to include other important ESG requirements towards more comprehensive ethical sourcing standards

Our employees receive training on modern slavery risk management during Code of Ethics training, completed every two years. In FY23, we will roll out further dedicated modern slavery awareness training.

In FY22, we engaged 203 unique new suppliers and we continue to assess and identify high risk areas and suppliers in our supply chains, through robust risk assessment framework in line with our existing risk management policies. One example risk identified was the use of polysilicon in the manufacture of solar panels, for which our supplier demonstrated appropriate steps with regard to modern slavery assessment. We continue to work with our suppliers in these areas to understand their operations and minimise the risk of modern slavery.

Extracting minerals contained in our vehicle batteries also carries a high risk of forced and child labour and other human rights abuses, and this risk is managed by Toyota globally in the manufacture of our products. As part of a TMC global initiative, our Service, Parts and Accessories team conducts an annual conflict minerals survey with our suppliers to confirm no conflict minerals are present in their supply chains.

See our [Anti-Modern Slavery Statement](#) for more information.

Dealer network

Toyota and Lexus dealers are the primary touchpoints for our customers and local communities, and at the frontline of providing mobility solutions. Our national network of Toyota and Lexus Dealers are essential to our business, and provide indirect economic benefits to many Australians in both metropolitan and regional communities (see [p. 27](#)). We engage with our dealers through regular communications, conferences and events, as well as meetings between Toyota Australia and members of the National Toyota Dealer Association (NTDA) or the Lexus Communications Council (LCC). We aim to support dealerships to navigate the transforming automotive industry and contribute to Toyota's strategic ambition to become a mobility provider, creating happiness for all.

Toyota Australia fosters deep relationships with our dealers:

- Listen and respond to their feedback
- Provide industry training and professional development
- Provide education on Toyota Australia's strategic objectives
- Recognise dealer success through our annual President's Award and Excellence Awards
- Provide timely and efficient vehicle flow through strategically located vehicle logistics hubs to minimise delivery lead times
- Support dealer businesses through inclusion in future-focused initiatives and diversified mobility services, such as KINTO rental and car sharing.

Toyota and Lexus dealers in Australia

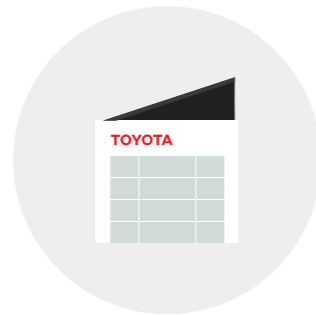

Toyota

192
dealers

275
principal and branch sites

16,854
dealer employees



Lexus

22
dealers

29
principal and branch sites

994
dealer employees

Supporting our dealers

The automotive industry is changing; customers expect new and more flexible mobility offerings and stronger sustainability performance from the brands they trust. This influences Toyota Australia's business strategy, and how we engage with our dealers, by turning risks into opportunities for growth, for example in developing new mobility solutions such as KINTO.

Toyota Australia's long-term strategy is to further develop our end-to-end mobility offerings, and to provide a range of solutions to cover the diverse needs of today's and tomorrow's customers, whether owning, renting or sharing vehicles. Toyota dealers will be important contributors to connecting each customer to these new mobility solutions and services. We are already beginning to bring these new mobility products and services to customers through our dealer network thanks to KINTO, alongside other offerings such as Toyota Certified Pre-Owned vehicles. See [p. 14](#) for more information on KINTO.

Supporting our dealers' growth, operational improvements and skills is also indispensable to Toyota Australia's business success and the positive impact we can make to the world. See [p. 37](#) for more information on how we support skills development and career progression for dealership sales professionals.

CASE STUDY

Solar panel group buy

One of the ways Toyota Australia supports our dealer network is by leveraging our scale to negotiate bulk pricing and arrangements for utilities. This helps us create positive financial outcomes for dealerships, especially those in regional areas.

In FY22, Toyota Australia negotiated a national solar panel group buy program for our dealer network through our partnership with AGL, which reduced the purchase costs for our dealers and provided them with end-to-end services including advice, installation, and ongoing support. This program helps our dealers to improve their energy efficiency and environmental performance, which also provides operational cost and reputational benefits.

As at June 2022, 39 dealers had submitted proposals to participate in this program, of which 11 have been accepted and seven installed. AGL has contacted over 100 additional dealers with supporting information to prepare proposals for submission.

Dealer satisfaction and recognition

We recognise and reward metropolitan and rural dealers across Australia for the value they provide to the ongoing and mutual success across Toyota Australia, dealers, Toyota customers, local communities and the environment. Our annual awards, and associated prizes and benefits, encourage dealers to embody Toyota's Kaizen philosophy for continuous improvement, contributing to creating happiness for all and positive environmental impact beyond Toyota Australia's direct control.

The Toyota President's and Excellence Awards reward performance in areas such as:

- Customer experience
- Employee happiness
- Fleet management
- Environmental performance

FY22 Dealer Satisfaction Index

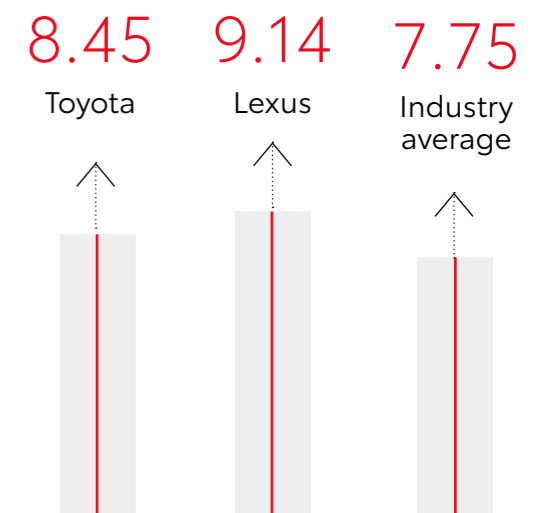

Community investments and partnerships

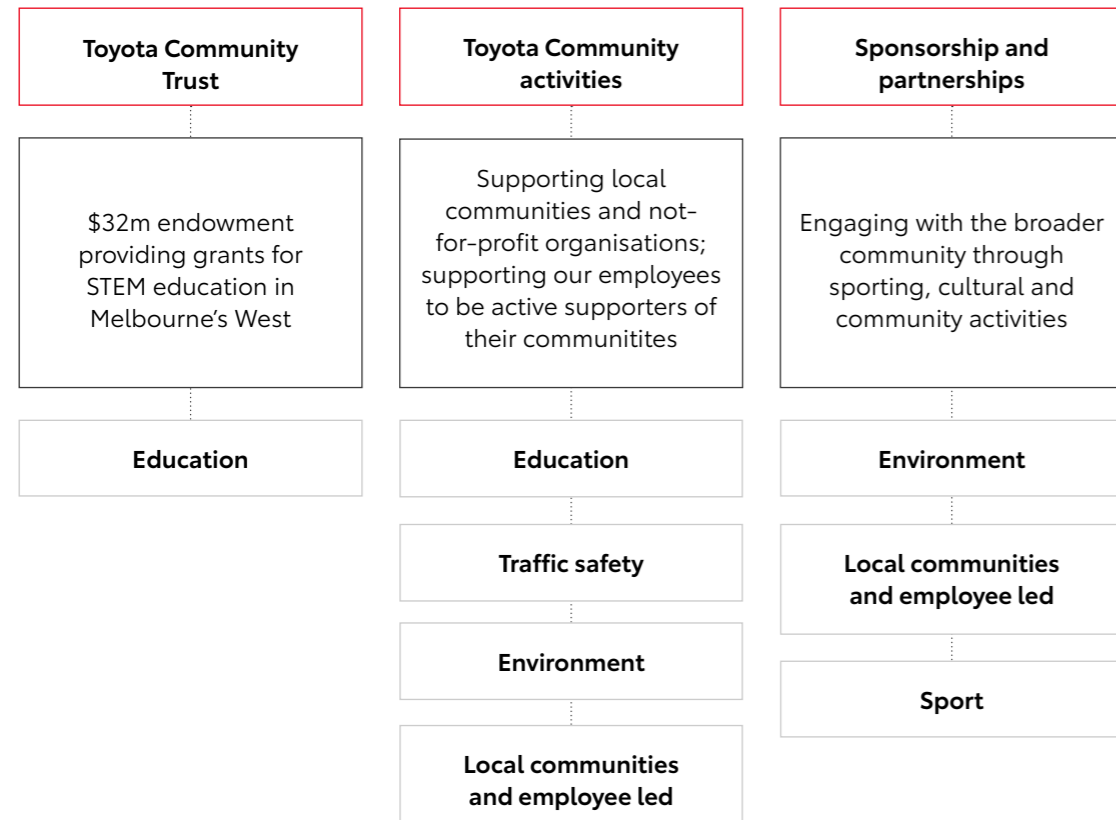

Toyota Australia is passionate about supporting our local communities. Our community initiatives target key social areas where we believe we have the greatest ability to make an impact. We do this through the Toyota Community Trust, philanthropy and sponsorships.

Our reinvigorated social contribution strategy continues our commitment to philanthropy and donations, but aims for greater impact through partnerships, and ultimately focuses on creating measurable social impact by partnering with others to address key issues that matter to Toyota Australia and Australian society. The focus areas of the strategy align with TMC's global priorities: environment, traffic safety, education and local community issues.

In FY21, our President declared a target of 1% of pre-tax profits going to social contribution and impact, to spread the benefits of Toyota Australia's success to Australian society. In FY22, this equated to \$3,560,000, calculated as 1% of the prior year's pre-tax profit. In FY22, we spent \$3,390,000 on social contributions, just below our target.* Our strategy to close the gap between our contributions and our target includes deepening our collaboration with existing community partners, further donations and long-term investments in areas related to mobility, carbon neutrality and local needs.

* This includes social impact, partnerships and philanthropy projects. Commercial sponsorships are separate to our 1% social contribution target.

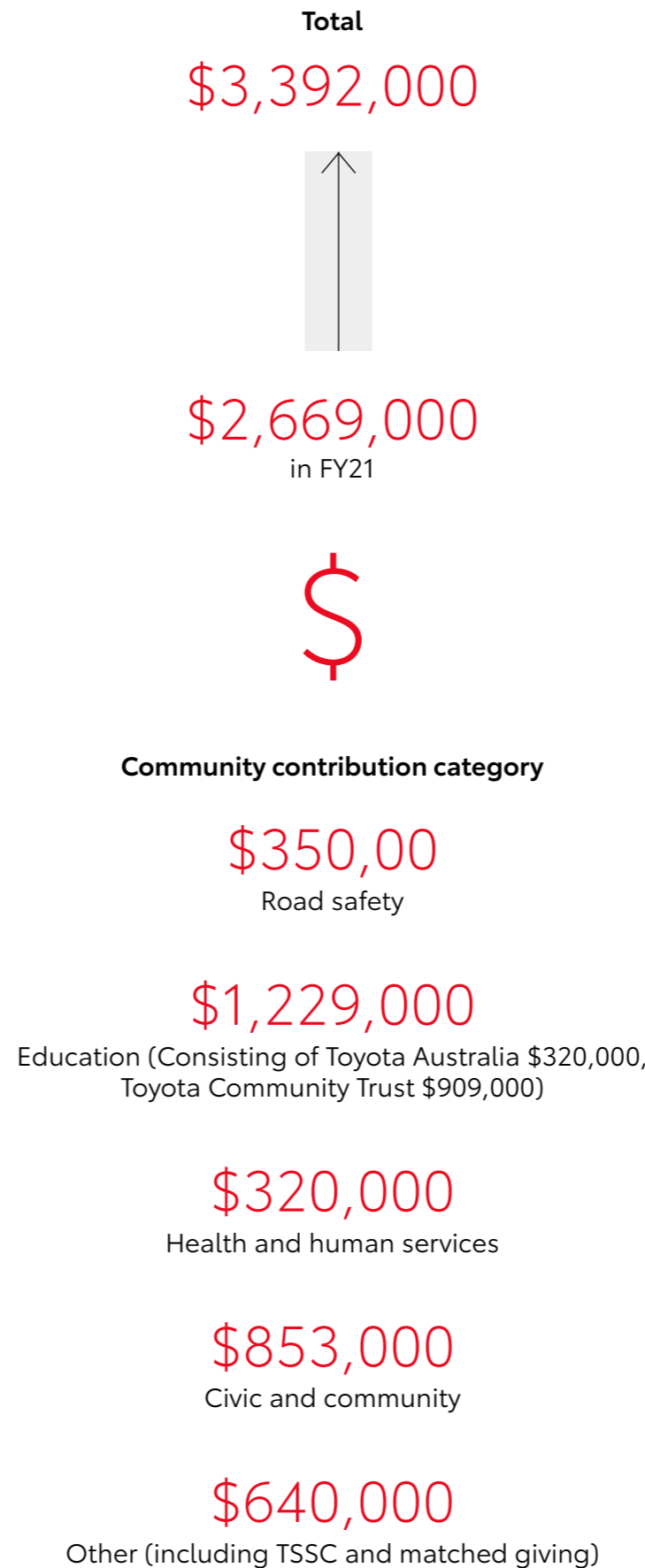

Social impact

Our social impact activities and projects target areas that are beneficial to both Toyota Australia and society, leveraging our mobility expertise. As our social contribution strategy matures, we will identify specific activities to build social impact. This will be based on partnerships and investments in research to solve problems facing Australian society. See [p. 16](#) for how we already contribute to improving road safety for all with innovative connected and automated vehicle technologies.

STEM skills for Australians

The Toyota Community Trust (TCT) supports initiatives to develop science, technology, engineering and maths (STEM) skills and education in the Australian community. In FY22, the TCT provided \$909,000 in support of our community partnerships, up from \$750,000 in FY21. For more information see [p. 33](#) or visit our [Toyota Community Trust](#) webpage.

Toyota Australia is passionate about encouraging Australian youth to pursue higher education in STEM (science, technology, engineering and mathematics). TCT supports a range of initiatives aimed at improving the supply and professional capabilities of STEM teachers, particularly in underserved regions, and facilitating mentorship of students. For further information on initiatives and the Toyota Australia Scholarship Program, visit our [Toyota Community Trust](#) webpage.

CASE STUDY

In2Science Mentor Leaders Program

In2Science facilitates STEM mentoring in schools. In FY22, In2Science and TCT developed and rolled out the inaugural Mentor Leaders Program, which aims to prepare professional mentors for engaging secondary students with aspirations to enter STEM fields. Mentors are volunteers from a range of companies, including Toyota Australia.

At the end of the program, 100% of mentors felt better equipped to coach their junior colleagues and reported that they believed their skills across persuasion, time management, creative problem solving, collaboration, active listening, empathy and communication had improved. Toyota Australia expects that the program will have a positive impact on the student participants' STEM aspirations.



Philanthropy and donations

Toyota Australia encourages our employees to support causes they believe in. Through our Matched Workplace Giving Program, Toyota Australia matches the donations our employees make to eligible charities. This year, Toyota Australia donated more than \$45,000 through this program.

We also provide our employees with volunteering leave so they can contribute to the community projects that mean the most to them. In FY22, employees participated in projects such as:

- Building habitat boxes for local wildlife with the Port Philip Eco Centre
- Repurposing surplus food into 870 Christmas meals with FareShare for the Father Bob Maguire Foundation
- Volunteering with the RSPCA.

In addition to matched giving and volunteering, the annual Toyota Employee Community Grants Program provides up to 40 employees the opportunity to win a \$1,000 grant towards a non-profit community group or charity organisation of their choosing. Since the program's inception in 2013, we have provided \$340,000 in grants to local sporting clubs, primary schools, youth programs and other groups.

For more information on our Workplace Giving and Community Grants programs, visit our [website](#).

CASE STUDY

Local council community grants

We support community groups in Hobsons Bay (where our Toyota Centre of Excellence is located) and Port Phillip (where our headquarters are located) through grants that support council programs. The grants help small community organisations to purchase equipment and other resources to support their organisations and local communities.

In FY22, we allocated \$30,000 in grants to Port Phillip Council. Through the Hobsons Bay City Council 'Make It Happen' Program, Toyota Australia supported 21 organisations including schools, neighbourhood cooperatives, community and centres and youth sports programs, through grants totalling \$40,000.

Visit our [website](#) for more information on our community contributions.



Sponsorships

In addition to our 1% community contribution target, we provide sponsorships for community events and sporting teams. In FY22, Toyota Australia provided \$300,000 in sponsorship funding.

CASE STUDY

Greening Australia with Planet Ark

Toyota Australia and Planet Ark have been working together since 1999 to build a greater understanding of how people can create a better environment for future generations. Each year, Toyota dealers and staff roll up their sleeves to get their hands dirty as part of our involvement in National Tree Day. This year, Toyota Australia contributed the following to these national efforts:

- \$300,000 in sponsorships provided by Toyota Australia
- Dealer participation in local activities
- Toyota Australia employee involvement in tree planting
- Toyota Australia ambassador attendance to events

The Planet Ark National Tree Day team, in partnership with Toyota Australia, established the Seedling Bank in 2019 to supply native seedlings to schools and community groups. So far, 90 groups have received funding through The Seedling Bank and almost 39,000 seedlings have been planted around Australia*.

*As per the National Tree Day website at 16 September 2022, i.e. outside the FY22 reporting period



Skillsets for the Australian community

Toyota Australia helps to strengthen the Australian economy by sharing our problem-solving knowhow with not-for-profit enterprises and small businesses, equipping organisations with skills to more effectively support their communities. We are also passionate about inspiring young people to pursue careers in STEM-related fields, and support quality mentorship and education programs. By arming more Australians with skills for the future, we all benefit from the innovation these people can drive in a changing world.

See **p. 37** for information on how we support skills development across Toyota Australia and our dealers.

Toyota Production System Support Centre (TSSC)

Toyota Australia believes we can contribute to a stronger and more

skilled society by sharing proprietary Toyota Production System (TPS) knowledge and processes. We do this through the Toyota Production System Support Centre (TSSC). TSSC works with Australian small to medium-sized businesses, not-for-profits and social enterprises to solve problems and build a culture of continuous improvement, with the goal to strengthen the local economy and communities. We support organisations based on their potential to deliver long-term positive impact for their customers, and projects focus on helping them solve organisational challenges.

After two disruptive years due to COVID-19, TSSC held its first virtual conference in FY22. The event brought together past, present and new TSSC project organisations to share their TPS experience, learn from and connect with each other. Over 200 participants joined the conference from a range of industries, sharing their challenges and successes in adopting TPS.



TSSC virtual conference

Regional engagement

Through the Toyota dealer network and our community activities, Toyota Australia has a strong presence in regional communities across Australia. Toyota dealerships are locally owned and operated businesses whose contributions support local economies and employment. Dealers are also the face of Toyota Australia's community engagement initiatives. These include sponsorships of grassroots sports teams, local events and charities, and stepping up to provide disaster relief. For more information on Toyota Australia's community contributions across Australia, see [p. 31](#) or visit our website.

CASE STUDY

Teach for Australia

Teach for Australia is a not-for-profit organisation that sources high quality graduates and industry experts to become teachers in Victorian secondary schools. Teach for Australia sought TSSC's support to establish and maintain more effective processes to identify and process candidates based on school demand. TSSC supported Teach for Australia to implement clear criteria to guide how they time and prioritise candidate onboarding so they can better serve the Victorian education system.

Toyota Australia additionally supported Teach for Australia through the Toyota Community Trust, providing \$120,000 in funding to the Bring STEM Teachers to the West project.



CASE STUDY

Ability Works Australia

Ability Works Australia is a not-for-profit that aims to provide inclusive employment for marginalised communities to improve people's sense of self-worth and combat misconceptions about their capabilities in the workplace. In FY22, Ability Works Australia wanted to expand the work opportunities for assisted members who participate in Ability Works Australia's programs in its digitised record management operations, whilst maintaining production capacity to meet their customers' needs. TSSC supported Ability Works Australia to implement systems to simplify this work and make it accessible to more assisted members and establish a smooth production flow. As a result, the number of operational processes that have been simplified to make them more accessible to assisted members grew from one to five.

For more information, visit the [TSSC](#) webpage.

CASE STUDY

Dynapumps

Dynapumps is a pumping solutions provider for oil and gas, mining and general industries, with its head office located in Perth WA and sales and service centres in Vic and QLD. In FY22, Dynapumps approached TSSC for support to improve delivery in full, on time (DIFOT) and reduce the number of delay days supplying products to their customers. TSSC used structured problem solving to establish robust systems that build in quality at each step of the process, and established a strong feedback loop as part of the continuous improvement cycle. Through this activity, Dynapump's DIFOT improved by 18% and delay days were reduced by 90%.



Capable, accomplished people



Employees by location (excluding contractors)

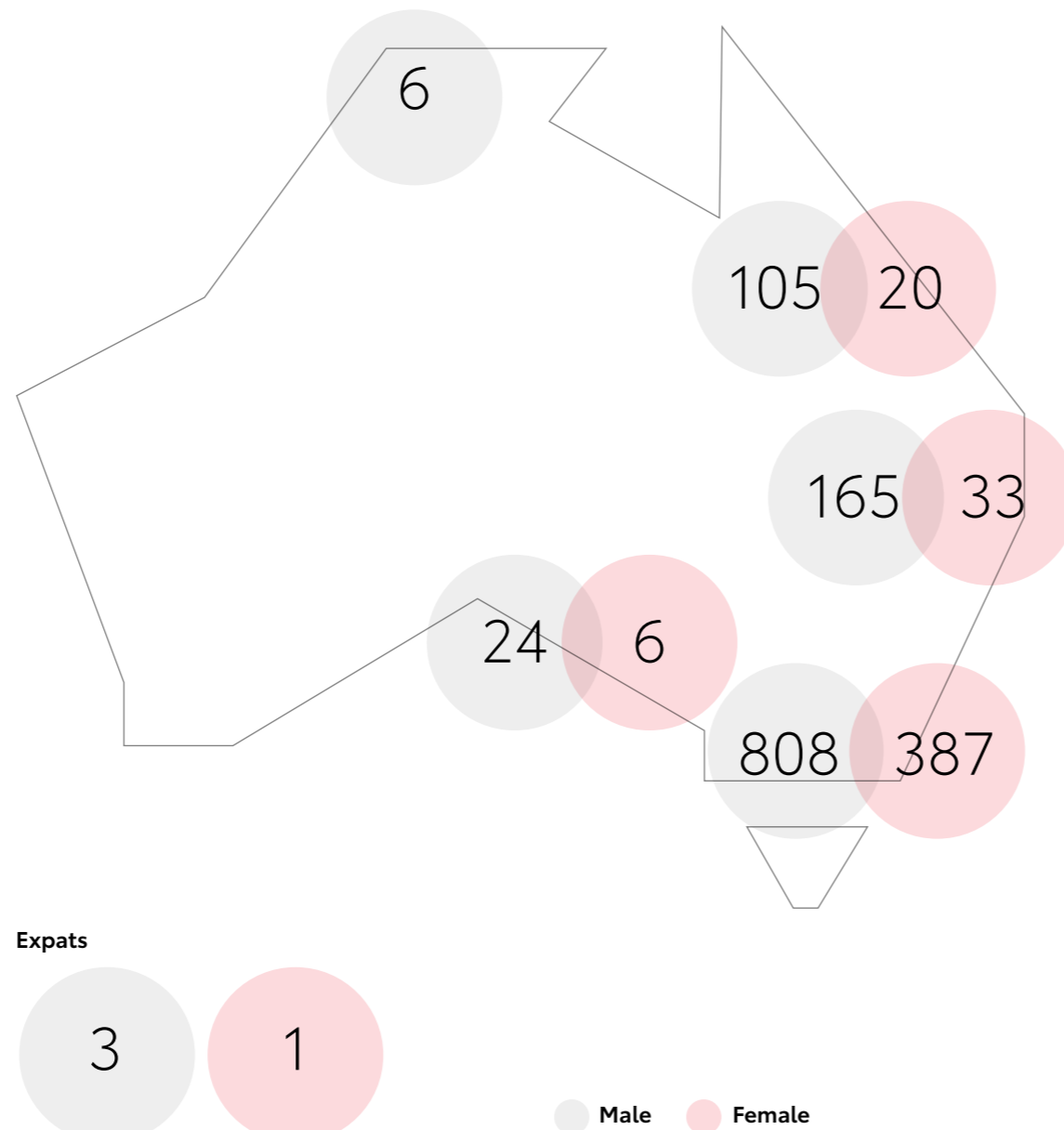

Workforce overview as at 31 March 2022

Employment type	FTE		Employee headcount	
	Male	Female	Male	Female
Part-time employees	6.5	27.5	8	25
Full-time employees	1198	444	1198	444
Part-time contractors	1	1.2	2	2
Full time contractors	95	35	95	35
Total headcount*			1303	506

* Note: the headcount covers all Toyota Australia employees including full-time employees, part-time employees, employees on fixed-term contracts, and casual and temporary employees. It also includes employees on leave of more than eight weeks, apprentices, tour guides, expatriates (Toyota Australia employees who are working overseas at affiliate Toyota locations), inpatriates (employees from Toyota affiliates working at our locations) and TMC subsidised employees. Full-time equivalent (FTE): Part-time and casual employees are counted according to the proportion of full-time hours they work. For example, if an employee works four days a week, they are considered 0.8 FTE

Total new employee hires during reporting period by gender

99
male **49**
female

Total employee turnover during reporting period by gender

88
male **40**
female

Employment by type as at 31 March 2022*

Employment type	FTE		Employee headcount	
	Male	Female	Male	Female
Permanent	940	378	969	393
Fixed term	118	50	124	51
Contract	96	36	97	38

* Note: these figures do not include employees who are on leave of longer than eight weeks, apprentices, tour guides, expatriates and inpatriates.

Our Ambition

It is through our people that the Toyota Way is realised. Satisfied and skilled employees underpin our business success and drive innovation, so we support our employees to meet their potential and feel a sense of meaning and pride in their work.

Improving our people's capabilities is at the heart of our People and Culture strategy. We foster talent development by putting people first, and this supports Toyota Australia's business competitiveness. We challenge every member of our staff to contribute to the Toyota mission and vision.

Workforce engagement and communication

Employees are the heart of Toyota Australia. We would not be able to carry out our mobility and innovation work without them, so it is crucial that we foster an environment that supports an engaged and empowered workforce.

COVID-19 significantly changed the way in which we all work, and Toyota Australia employees successfully navigated these uncertainties. We are also now seeing significant shifts in the labour market, and employee retention is critical to our business. In this environment, active engagement and communication is more important than ever to make Toyota Australia a great place to work, where employees feel a sense of belonging and valued for their contributions.

We use a number of channels to give our employees opportunities for

their voices to be heard, and for them to ask questions of Toyota Australia leadership, including:

- Regular employee bulletins
- Annual engagement and enablement surveys
- Toyota Torque town halls.

Our philosophy of continuous improvement relies on the input of our people at all levels. In FY22 we set up an activity for TPC employees to contribute their ideas for improving our operational environmental performance (see [p. 23](#)).

Toyota Australia supports worker rights to organise, to fairly manage the relationships between businesses and employees. In FY22, 27.5% of our employees are covered by the Toyota Australia 2018 Workplace Agreement. The agreement provides clear processes for significant operational changes and a maximum ten-week consultation period.

CASE STUDY

Workstyle 2.0

In FY22, Toyota Australia introduced Workstyle 2.0 – Return to Office. This trial aimed to improve our employees’ experience and productivity, integrating our learnings from COVID-19 about flexible work into a new hybrid work model. Employees were encouraged to discuss their working arrangements with their managers to find a split that best suited their flexibility needs, their role and business needs. After a successful trial period, Toyota Australia formally introduced Workstyle 2.0 to all corporate sites.

We introduced a number of initiatives to enable our employees to work comfortably and productively from home over the past years. A Working from Home Allowance was introduced to assist our employees with the cost of working from home. In 2020, we partnered with JB Hi-Fi to give our employees financial support to purchase equipment to assist them with setting up their home workspaces, this initiative was continued in 2021.

Employee engagement and enablement

Engaged and empowered employees create a virtuous cycle for better performance and better culture. Toyota Australia conducts an annual Employee Engagement and Enablement survey to give employees the opportunity to share their perspectives on what we do well and areas where we can improve. The FY22 results are an improvement on FY21; however, employees have indicated several areas for Toyota Australia to improve on.

Engagement and enablement results %

	FY22	FY21
Engagement	82	81
Enablement	72	70
Response rate	93	95
Would recommend Toyota as a good place to work	84	83
Intend to stay long term	72	72
Given opportunities to learn and develop	78	75

Area for improvement	How TMCA is responding
Addressing poor performance	Improving manager capabilities to coach employees and address performance
Enhancing employee understanding of career pathways	Building manager capability training sessions and relaunching Toyota Australia’s Career Management Framework
Elevating diversity and inclusion	Working with diversity and inclusion Action Teams to identify and address opportunities for improvement going forward
Improving the efficiency of decision-making processes	Further study to identify and remove blocks to decision making, especially at a business unit level

These areas for improvement were also identified in FY21 and remain a challenge for Toyota Australia to address.



Workforce skills and development

Toyota Australia provides employees with ongoing opportunities to grow and to reach their potential during their careers with us. This not only supports their own career development, but also helps to drive innovation at Toyota Australia so we can solve ever more challenging problems. Mobility is evolving, so broadening and deepening our employees' capabilities is critical to navigating and thriving in this changing environment.

In FY22, Toyota Australia strengthened its development opportunities for managers and leaders to improve how they can support the employees they manage and transform our business.

Senior Managers

A number of senior managers were invited to undertake inaugural development programs designed to tackle significant transformational business challenges, such as:

- Australian Leadership Development Program
- Australian Executive Development Program

Managers

Undertook a series of workshops to enhance their management of remote and hybrid teams, focusing on skills such as:

- Virtual leadership
- Performance management
- Having difficult conversations in a productive way

Our managers support their teams through performance reviews and individual career support. In FY22, 1,099 employees (74%) participated in our annual performance review process. This figure includes all employees except TPC employees, Vice Presidents and the President. Managers work with their direct reports to plan for ongoing individual skill development over the year. Employees can create Individual Development Plans to help them meet the requirements of their current role, improve their soft skills and realise their career aspirations. Priorities can focus on enhancing an existing strength or improving skills where employees have a gap in their capabilities.

As part of our shift to being a mobility company, employee development is essential to our transformation.

This year, average hours of training per employee significantly increased from 7.2 hours in FY21 to 20 hours in FY22. This includes all employees. The majority of this increase occurred at the senior professional and manager level. The increase in average training hours was due to new training introduced to support managers after COVID-19, and increased uptake global training provided by TMC through successful enrolment initiatives by Toyota Australia's professional development team.

Toyota Australia's approach to setting an Individual Development Plan

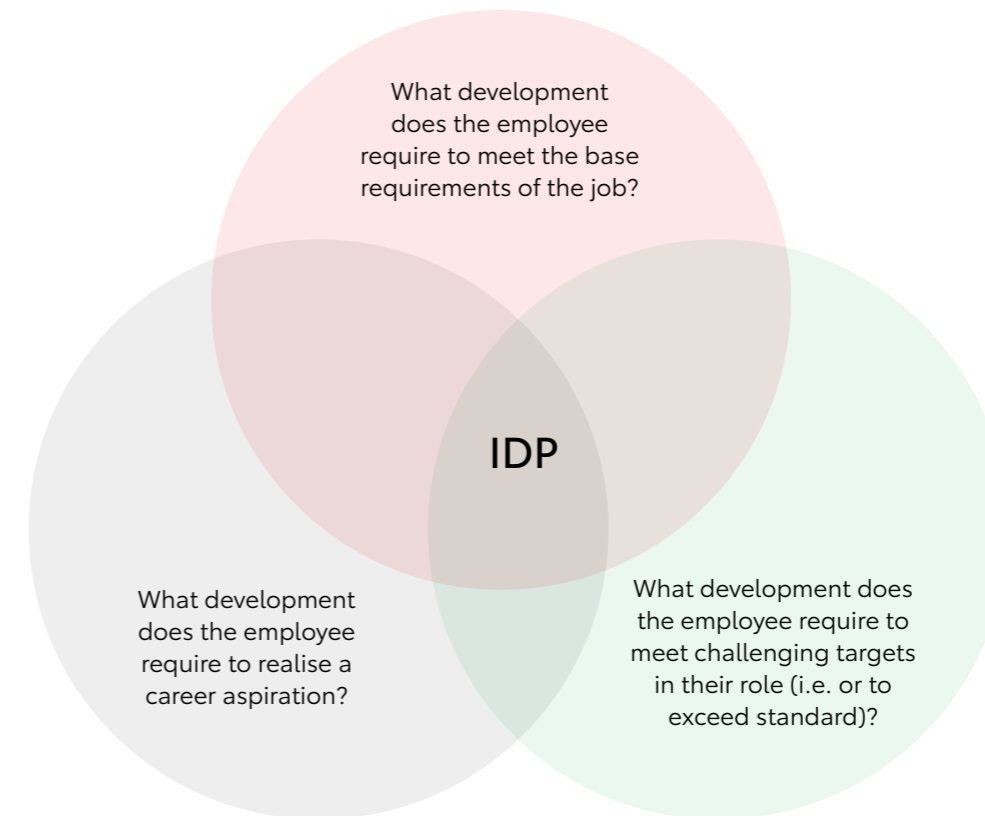

Agile workforce

A key pillar of our People and Culture Hoshin is to develop a high-performance culture where we inspire and empower our people to grow and achieve, creating new possibilities and happiness for all. By developing our team culture and capabilities, we aim to increase Toyota Australia's competitiveness, as this will enable Toyota Australia to respond to market and customer needs with agility. We aim to develop a more adaptable workforce and agile workstyle, with growth opportunities for all of our people. To achieve this, we are increasing cross-divisional collaboration between departments where more employees can work together and learn from each other. This approach facilitates greater internal mobility for employees, who can develop multi-functional skills and introduce fresh ideas to enhance our work. We encourage employees to build interesting and satisfying careers, improving happiness at work and driving new solutions to challenging problems.

In line with this approach, in FY22 we updated our Career Progression Framework to a Career Management Framework, continuing our shift away from rigid linear progression pathways, to instead focus on building capabilities. This will facilitate more flexible career building. We also facilitate flexible career growth through the intra-company transfer program, with twelve employees taking part in the program during FY22. This gives our employees the opportunity to gain experience at Toyota affiliate companies overseas and provides

valuable knowledge sharing across Toyota which helps us build our business. Our next Hoshin plan will further develop our strategy to embed flexible career pathways within Toyota Australia.

Dealership staff

While our dealers and their employees are not employed directly by Toyota Australia, they have a critical role in Toyota Australia's

success as frontline ambassadors for our brand. It is important that we retain valuable dealer staff by keeping them engaged. Toyota Australia therefore continues to invest in skills development for our dealer network and improve our dealer communication. A current area of focus is to provide dealership employees with more clarity about career pathways, and to help them feel more connected to Toyota Australia's 2030 vision.



CASE STUDY

Developing Toyota fleet management professionals

The Toyota for Business Professionals (T4BP) program was established in 2021 to strengthen the relationship between Toyota Australia and Toyota Fleet Management, with the support of the Australian Fleet Management Association (AfMA). The program focused on continued professional development to deliver outstanding fleet customer experiences, increase customer referrals and grow small business contract sales. Following the first year of the program, we recognised fifteen dealerships as being T4BP accredited, and awarded over \$35,000 in Sales Society Reward Dollars to dealership staff who successfully achieved the program assessment criteria. The T4BP program will continue in the second half of 2022.

In FY22, we also continued our partnership with AfMA to provide two scholarships for the Diploma of Leadership and Management to women and young fleet management professionals under 30, to grow their careers in an industry that has traditionally been male-dominated. We believe that a more diverse working environment can create a better culture, better business performance and better employment outcomes in the long term.



CASE STUDY

Toyota Network Training program

We provide opportunities for career growth to Toyota dealer employees through the Toyota Network Training (TNT) program. The program provides nationally recognised and accredited apprenticeships, creating pathways into the mechanical sector of our Toyota and Lexus dealerships. In FY22, 731 TNT participants attended training at Toyota Technical Training Centres or at TAFE, while also receiving on-the-job learning, training and support. This helps dealer employees to pursue careers they are passionate about, while also increasing the number of skilled workers for our dealers, so they can grow their businesses and serve their customers.

In FY22, several TNT participants competed in the WorldSkills National Championship, Australia’s biggest vocational education and excellence competition. TNT apprentice through TAFE Queensland, Toby Seibel, was awarded the National Gold Medal for Automotive Mechanics. This was a great outcome for Toyota Australia and our dealers, demonstrating the professional excellence of our apprentices and technicians.



Diversity and inclusion

We strive to make Toyota Australia a workplace where all employees feel included, valued and free to bring their authentic selves to work. Diversity of perspective helps us navigate our changing industry and develop new and inclusive mobility solutions to meet the needs of all Australians. Our Annual Corporate Business Plan identifies inclusion and growth as key to strengthening our workplace culture.

Our Diversity and Inclusion Council aims to increase the visibility of diversity and inclusion within the business and embed initiatives into our operations. Our Diversity Action Teams, established in FY21, have continued to gain momentum this year. They have delivered a range of initiatives within Toyota Australia to drive a greater sense of belonging for all.



Diversity and Inclusion Council

Diversity Action Teams				
Revamped careers website to increase the visibility and accessibility for diverse people				
Introduced a calendar of cultural events, to spread awareness and promote events				
Diversity and Inclusion Council	LGBTI+	Indigenous affairs	Gender equality	Disability advisory
<ul style="list-style-type: none"> Introduced Gender Affirmation leave Updated Toyota Australia Blood Donor Policy 	<ul style="list-style-type: none"> Promoted inclusive pronoun awareness Promoted IDAHOBIT 2022 LGBTQI+ Allies Program 	<ul style="list-style-type: none"> Planning and preparation of Toyota Australia’s first Reconciliation Action Plan (RAP) Initiatives for National Reconciliation Week and NAIDOC Week 	<ul style="list-style-type: none"> Women’s mentoring program Toyota Women’s Conference Unconscious bias training 	<ul style="list-style-type: none"> Implemented Workplace Adjustment Procedure Planning and preparation of Toyota Australia’s first Disability Inclusion Action Plan

Despite progress on gender diversity in recent years, Toyota Australia's workforce composition continues to reflect the traditionally male-dominated character of the automotive industry, particularly at more senior levels. However, we believe we can continue to do better to provide policies and an inclusive environment which can attract and retain more women amongst our ranks. In order to improve women's representation at senior levels of management, we provide targeted professional development programs to address potential barriers to the workplace.

Following a successful women's mentoring pilot program in FY21 to support women to develop their careers at Toyota Australia, we expanded the program in FY22 to include participants from Toyota Finance and our insurance underwriter, ADICA (Aioi Nissay Dowa Insurance Company Australia). Mentees receive professional development guidance to pursue satisfying Toyota careers, and mentors are able to strengthen their managerial and leadership skills. See our [2021 Sustainability Report](#) for more information on this program.

The results of our annual gender pay gap review were consistent with the prior year, finding that female employees' salaries had a 2.4% difference compared to male counterparts' salaries.

During FY22, we received one complaint of discrimination. Toyota Australia undertook an investigation that found the allegation was not substantiated, and we subsequently took steps to address the related workplace interaction. This matter is now closed.

To continue to improve women's access to the workforce, we retained our Work180 endorsement, which screens Toyota Australia to ensure we have policies and benefits in place to support women's careers. These include:

- Gender neutral parental leave policies
 - Fourteen weeks paid parental leave at full salary for primary carers, in addition to government funded parental leave
 - Four weeks paid parental leave for secondary carers
 - Continuation of superannuation payments while on both paid and unpaid parental leave (up to 38 weeks)
- Domestic and family violence leave above legislated requirements
- 2025 target of 40% women in the workforce

Percentage of female staff by category in FY22

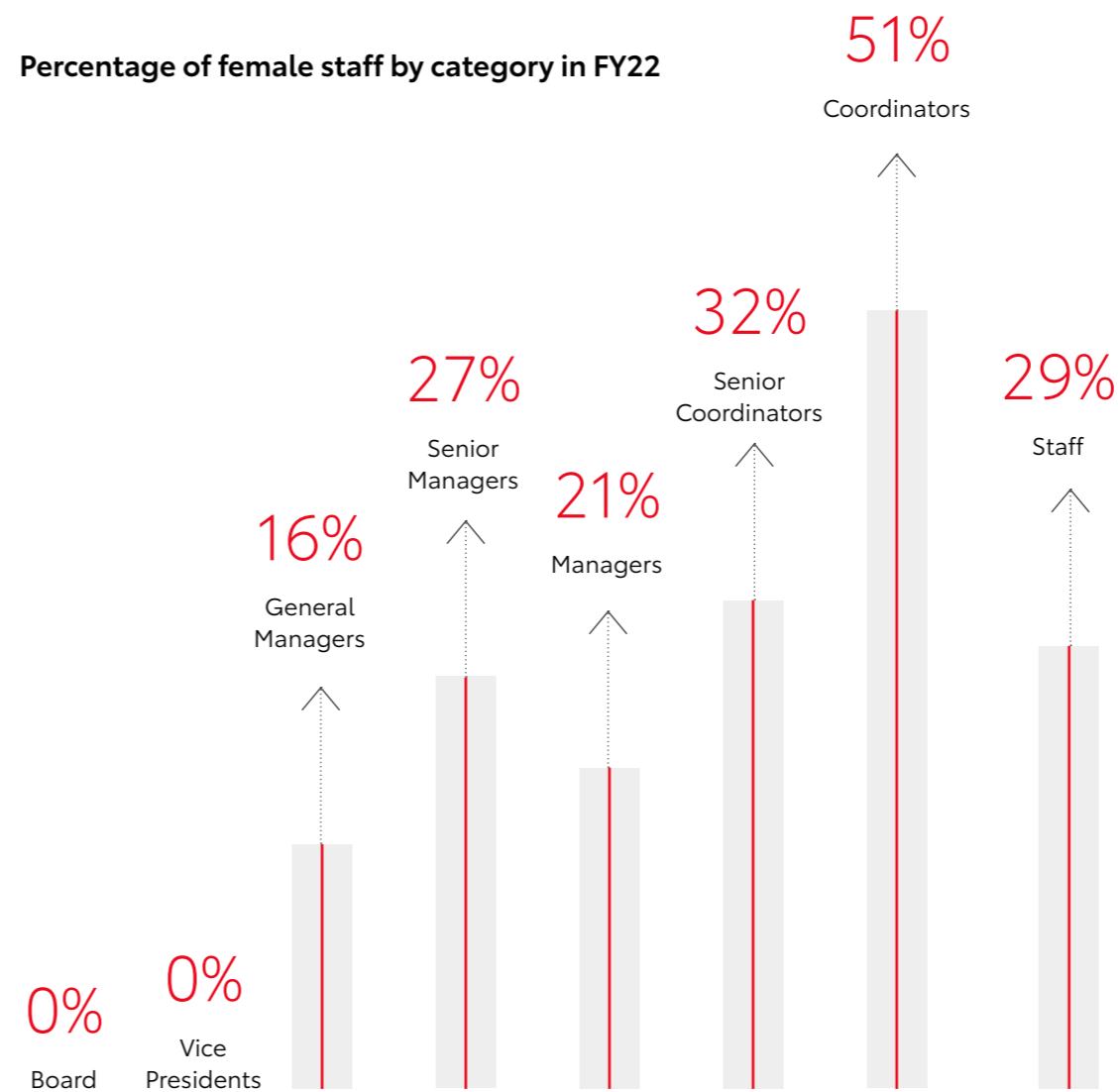

FY22 parental leave

	Female	Male
Parental leave taken	45	39
Returned to work after parental leave	45	39
Still employed 12 months after return to work	41	39
Still on parental leave	4	0



Employee health, safety and wellbeing

Health and safety

The safety of our employees is critical to their happiness, the wellbeing of their families and communities, Toyota Australia’s reputation as a responsible employer and our operational continuity. Toyota Australia takes a proactive approach to identifying and addressing any health and safety issues at all our sites. Our policies and procedures apply to all workers, operations and activities.

We manage health and safety through:

- Safety business plans and regular risk assessments
- Risk management procedures
- Encouraging employee reporting on both actual and near-miss incidents
- Health and safety committees at each operational site
- Health and safety management training for managers
- Day-to-day health and safety issues escalated to senior management as required and reported monthly
- Immediate escalation of critical hazards and incidents to the Risk and Compliance Committee

- Safety management system certified to AS/NZS ISO 45001:2018. ISO 45001 certification supersedes Toyota Australia’s previous National Audit Tool (NAT) certification, as WorkSafe Victoria confirmed ISO 45001 certification satisfies self-insurance requirements.
- External assessor audits every 12 months, and Victoria WorkCover Authority audits every three years.

Lost time injuries in FY22

FY22 health and safety	
Injury classification	Total
Lost time injury*	16

* Work injury resulting in the inability to work for at least one rostered working day or shift after an incident.

Lost time injuries reduced to 16 from 38 in FY21, primarily due to Hazardous Manual Handling Awareness training for warehouse staff.

Toyota Australia provides employees a range of training programs on health, safety and wellbeing, including:

- Mental health (266 participants)
- Work health and safety legislation, policies and procedures (531 participants)
- First Aid eLearning (670 participants)
- Remote working safety and ergonomics

The numbers above reflect the number of employees who have undertaken training in FY22. The training programs are not a yearly requirement.

Wellbeing

Toyota aims to create a psychologically safe work environment for our employees, where everyone is comfortable to contribute new ideas and develop rewarding careers. This is how we can help to improve our employee’s happiness.

To support good mental health in the workplace, our Employee Assistance program provides free and confidential counselling and health services from psychologists, dieticians and exercise physiologists to employees and their families.

In October 2021, Toyota Australia launched the Mental Health Heroes program for National Mental Health Month. The program aims to increase awareness of mental health, facilitate open discussions of mental health across Toyota Australia, and acknowledge employees who have made a difference to others in the mental health space through peer nominations.

We have also launched the Toyota Wellness Centre, which is free for all employees. The facility is staffed with trainers and exercise class instructors to support employees.

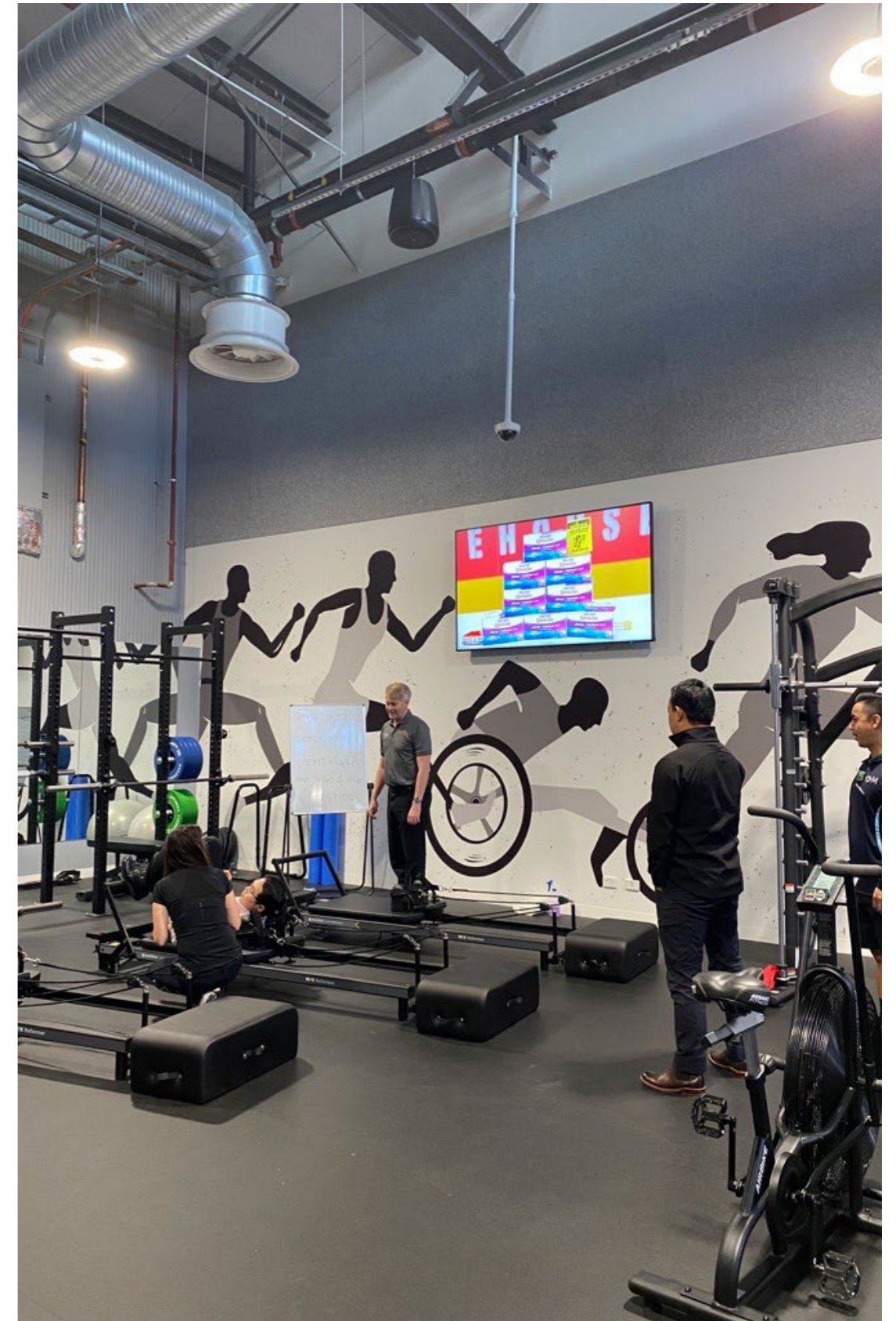

Appendix

Data tables

Reimagined mobility experience

Customer engagement and satisfaction (%)

	2021/22	2020/21	2019/20	2018/19	2017/18
Net promoter score (sales)	83.6	82.7	82.6	82.7	83.4
Guest Satisfaction Index (sales)	94.1	94.0	93.9	94.0	94.2

Safer, better vehicles and technology

Government funding

	2021/22	2020/21	2019/20	2018/19	2017/18
	\$1,513,600	\$20,912,978*	\$1,714,213	\$12,491,065	\$36,347,076

* Includes \$18 million in JobKeeper payments, which Toyota Australia has since returned to the Federal Government.

Political lobbying

Toyota is apolitical and does not make political contributions.

Reducing environmental impacts

Sales of hybrid and zero emissions vehicles (Toyota and Lexus combined)

	2021/22	2020/21	2019/20	2018/19	2017/18
Hybrid sales	73,027	60,699	38,139	16,102	11,135*
Total sales	234,080	220,403	215,722	223,096	229,258*
Hybrid percentage of total sales	31.1	27.5	17.7	7.2	4.9*
Zero emissions battery electric sales*	72	0	0	0	0
Zero emissions hydrogen sales [^]	17	15	0	0	0

* New to 2021/22 with introduction of Lexus UX 300e.

[^] Hydrogen fuel cell electric Mirai figure includes sales to large fleet customers, Toyota Australia's company fleet and KINTO.

Weighted average fuel economy of light passenger and commercial fleet sales FY22

Average fuel consumption (L/100km)*	
Toyota sales	6.9
Lexus sales	6.8
Total sales	6.9

* Average fuel consumption (L/100km) weighted by FY22 sale volume of Toyota and Lexus light duty vehicle models. Average does not include heavy vehicles. Fuel consumption values by model used in this calculation are drawn from fuel consumption data submitted to the Australian government for certification and labelling.

Greenhouse gas emissions (tCO₂-e)*

Source	2021/22	2020/21	2019/20	2018/19	2017/18
Scope 1	11,876.77	10,826	9,431	9,836	33,066
Scope 2	11,921.34	12,083	13,947	13,306	57,588
Scope 3 [^]	100,357.99 **	99,691	50,484	71,607	17,039*
Total	124,156.10	122,601	73,862	94,749	107,693

* From FY14–FY18, Toyota Australia was required to report under the NGER Act, but since the closure of Altona manufacturing facility, which reduced the company's scope 1 and 2 emissions, Toyota Australia no longer meets the NGER Act reporting threshold. This table reflects the baseline established in 2018 for our operations as a sales, marketing and distribution company.

** Scope 3 emissions have increased as the dataset has become more accurate and complete, in particular incorporating a more detailed breakdown of marketing and IT activity sub-categories

Emissions sources – inclusion and data quality

	Included	Partial	Planned
Scope 1	Fuels Natural gas	Refrigerants LPG	
Scope 2	Electricity from grid		
Scope 3	Fuel and energy-related activities Upstream transportation and distribution Capital goods [^] Business travel [^] Upstream leased assets*	Purchased goods and services+ Waste generation Employee commuting Downstream transportation and distribution Employees working from home#	Processing of solid products Use of solid products End-of-life treatment of solid products Franchises (dealerships)

Downstream leased assets included in franchises, and investments considered outside of organisational boundary.

[^] New sources measured in FY22. Business travel now includes road transport. Capital Goods now includes equipment and office furniture.

+ Goods and services – Advertising and Promotion and IT/Telecommunications categories broken down into sub-categories

Estimated using Climate Active framework for state-based assumptions.

* Upstream leased assets has been included within the emissions boundary in previous reports. It's inclusion was triggered in the initial boundary assessment as Toyota Australia leases assets from third-parties. The emissions of these leased assets, however, have been captured in scope 1 & 2 of each year inventory as the operational control is used as consolidation approach for the GHG inventory. FY22 assessment concluded that there are not emission associated to this category for the reporting year.

Solar power generation (kWh)

Location	2021/22	2020/21
Sydney Toyota Parts Centre	1,065,921	795,985 [^]
Brisbane Toyota Parts Centre	74,765	76,711
Altona Product Centre*	608,713	669,516
Altona Hydrogen Centre*	96,995	-
Total	1,846,394	1,542,212

* Note: In the 2021 Sustainability Report, we reported solar generation for the Altona Product Centre as the Altona Hydrogen Centre. This has been corrected in this report and correct data is provided in the table above.

[^] Estimated generation using 2018 and 2019 monthly average from August to March. The amount has been estimated due to issues with on-site monitoring equipment preventing accurate data collection. COVID-19 restrictions meant that work to repair data loggers was unable to take place for up to six months

Strong economy and thriving communities**Profits and sales (includes Toyota and Lexus vehicles)**

	2021/22	2020/21	2019/20	2018/19	2017/18
Net profit after tax (million)	250	332	129	206	137
Sales (numbers)	234,090	220,403	215,722	223,096	229,258

Dealer Satisfaction Index

	2021/22	2020/21	2019/20	2018/19	2017/18
Toyota	8.5	8.6	8.2	8.4	8.2
Lexus	9.1	9.1	8.9	7.1	8.4

Supplier spend* (\$ billion)

	2021/22	2020/21	2019/20	2018/19	2017/18
Service parts and accessories	0.3	0.3	0.3	0.3	0.4
Other goods and services	0.8	0.8	0.9	0.9	0.9
Total	1.1	1.1	1.2	1.2	1.3*
Direct purchase[^]					0.5
Total including direct purchase					1.8*

* Excludes manufactured vehicles purchased through Toyota Global.

[^] Direct purchase related to Toyota Australia manufacturing operations and is no longer applicable.

Number of suppliers

	2021/22	2020/21	2019/20	2018/19	2017/18
Service parts and accessories	72	71	95	135	134
Other goods and services	1174	1,127	1,361	1,531	1,800
Total	1246	1,198	1,456	1,666	1,934
Direct purchase[^]					48
Total including direct purchase					1,982
Number of new suppliers (included in total)	203	168	234	227	353

[^] Direct purchase related to Toyota Australia manufacturing operations and is no longer applicable.

Community contributions (\$ million)

	2021/22	2020/21	2019/20	2018/19	2017/18
Toyota community activities	2.26	1.91	2.2	1.6	1.6
Toyota Community Trust	0.93	0.75	0.6	0.9	0.2
Total	3.39	2.66	2.8	2.5	1.8

* Up to 2016/17 we used the London Benchmarking Group methodology to measure our community investment, which includes 'leveraged' third party contributions. From 2017/18, we have aligned our external reporting with our internal global reporting, which includes only direct contributions. Our past contributions, calculated on the same basis, averaged \$700,000-\$1 million.

Community contributions by category (\$)

	2021/22	% of total	2020/21	% of total	2019/20	% of total
Environment	0	0	0	0	8,000	0.3
Road safety	350,000	10.3	350,000	13.1	350,000	12.4
Education	1,229,000	36.3	1,199,000	44.9	1,141,000	40.6
Health and human service	320,000	9.4	370,000	13.9	573,000	20.4
Civic and community	853,000	25.1	108,000	4.0	100,000	3.6
Others - TSSC and matched giving	640,000	18.9	640,000	23.9	640,000	22.8
Total	3,392,000	100%	2,669,000	100%	2,812,000	100%

Capable, accomplished people

Workforce overview at 31 March 2022

Employment type	FTE		Employee headcount	
	Male	Female	Male	Female
Part-time employees	6.5	27.5	8	25
Full-time employees	1198	444	1198	444
Part-time contractors	1	1.2	2	2
Full time contractors	95	35	95	35
Total headcount*			1303	506

* The headcount covers all Toyota Australia employees including full-time employees, part-time employees, employees on fixed-term contracts, and casual and temporary employees. It also includes employees on leave of more than eight weeks, apprentices, tour guides, expatriates (Toyota Australia employees who are working overseas at affiliate Toyota locations), inpatriates (employees from Toyota affiliates working at our locations) and TMC subsidised employees. Full-time equivalent (FTE): Part-time and casual employees are counted according to the proportion of full-time hours they work. For example, if an employee works four days a week, they are considered 0.8 FTE

Employment by type at 31 March 2022*

	FTE		Employee headcount	
	Male	Female	Male	Female
Permanent	940	378	969	393
Fixed term	118	50	124	51
Contract	96	36	97	38

* These figures do not include employees who are on leave of longer than eight weeks, apprentices, tour guides, expatriates and inpatriates.

Percentage female employees by category

	2021/22	2020/21	2019/20
Board	0%	0%	0%
Vice Presidents	0%	0%	0%
General Managers	16%	14%	13%
Senior Managers	27%	22%	23%
Managers	21%	19%	20%
Senior Professionals	32%	31%	29%
Professionals	51%	50%	48%
Staff (other levels including contractors)	29%	17%	24%
Total	29%	28%	29%

Total new employee hires during reporting period by gender

	FTE	Employee headcount
Male	99	99
Female	48.4	49
Total	147.4	148

Total employee turnover during reporting period by gender

	FTE	Number of employees
Male	86.4	88
Female	38.53	40
Total	124.93	128

Employees by location (excluding contractors)

	Male	Female	Total
VIC	808	387	1,195
NSW	165	33	198
QLD	105	20	125
NT	6	0	6
SA	24	6	30
WA	0	0	0
Expats	3	1	4

Parental leave taken by gender

	Female	Male	Total
Parental leave taken	45	39	84
Returned to work after parental leave	45	39	84
Still employed 12 months after return to work	41	39	80
Still on parental leave	4	0	4

Employee engagement and enablement survey results (% favourable)

	2021/22	2020/21	2019/20	2018/19	2017/18
Engagement	82	81	78	79	78
Target	81	78	79	78	74
Enablement	72	70	65	67	66
Target	70	65	69	68	64

Health and safety

Injury classification	Total
Lost time injury*	16
Occupational disease	0

* Work injury resulting in the inability to work for at least one rostered working day or shift after an incident. Note: Previously we reported Lost time injury frequency rate. In a post-manufacturing environment in which hours are not tracked, we are now just reporting lost time injury numbers.

Our philosophy and values

The Toyota Guiding Principles

Honour the language and spirit of the law of every country and region, and undertake open and fair business activities to be a strong corporate citizen of the world.

Respect the culture and customs of every country and region, and contribute to economic and social development through corporate activities in their respective communities.

Dedicate our business to providing clean and safe products and to enhancing the quality of life everywhere through all of our activities.

Create and develop advanced technologies and provide outstanding products and services that fulfill the needs of customers worldwide.

Foster a corporate culture that enhances both individual creativity and the value of teamwork, while honouring mutual trust and respect between labour and management.

Pursue growth through harmony with the global community via innovative management.

Work with business partners in research and manufacturing to achieve stable, long-term growth and mutual benefits, while remaining open to new partnerships.

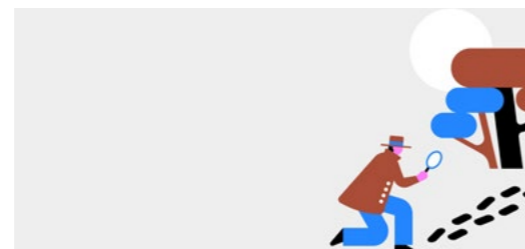

The Toyota Way

We act for others. We strive to keep the perspectives of our customers and stakeholders at the core of our efforts every day. We put ourselves in others' positions and go beyond the impossible.

We work with integrity. We always consider where today's work should take us and how it impacts those around us. We forge a path to our objective with integrity and honesty.

We drive curiosity. We take a personal interest in everything and ask questions to discover the mechanics behind the phenomena. Our curiosity mindset generates new ideas.

We observe thoroughly. We bring together hard data and combine it with seeing, feeling and interpreting the situation, exercising genchi genbutsu (going to the source) to discover the most creative and best solutions quickly.

We get better and better. We take ownership to sharpen the skills of ourselves and each other with heart, mind and body to meet the evolving needs of our customers.

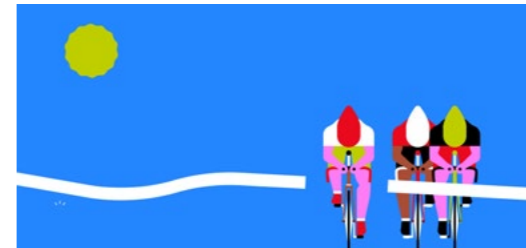
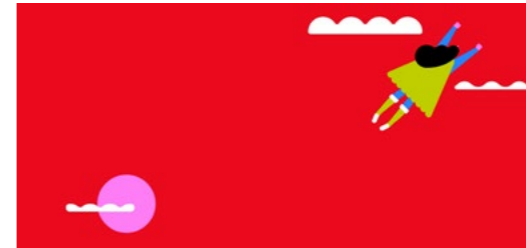

We continue the quest for improvement. We believe in the natural ability of people to change things for the better. We see every improvement, regardless of size, as valuable. We encourage both incremental and breakthrough innovative thinking. We seek to evolve with Kaizen (continuous improvement), never accepting the status quo.

We create room to grow. We focus on what is essential, eliminating waste and managing our resources carefully to create room to grow. We see this as the foundation for agility and the cultivation of new ideas for the future.

We welcome competition. We welcome competition without ego. Competition pushes us to improve and better serve our customers and society, creating more value and a better experience.

We show respect for people. We make the most of diverse perspectives, turning differences into fortitude as one team. With our fundamental respect for people, we create an environment where everyone feels welcome, safe and heard. We encourage everyone to contribute their best towards meaningful goals.

We thank people. We owe our existence to our customers, members, partners, stakeholders and communities. We say 'thank you' to everyone we encounter every day.

Information on Directors

The qualifications, experience and responsibilities of Toyota Australia's current Directors are detailed below.

<p>M Callachor Bachelor of Business, Marketing</p>	<p>Joined Toyota Australia in 1982. Worked as National Sales & Marketing Executive Director. Formerly General Manager of Lexus Planning Division, Lexus International. Vice President, Toyota Australia (1/6/2016 – 31/12/2017)</p> <p>Director – Federal Chamber of Automotive Industries (FCAI) (effective 1/1/2018), appointed Chairperson on 27/5/2020.</p> <p>Director – Toyota Finance Australia Ltd (effective 2/11/2017) and SCT Pty Ltd (effective 1/1/2018)</p> <p>Non-Executive Director – Toyota New Zealand Ltd (effective 1/7/2020)</p>	<p>President and Chief Executive Officer (effective 1/1/2018)</p>
<p>A Takemura (Appointed 1/1/2022) Bachelor of Foreign studies, Major in Arabic Diploma of Executive Management Program</p>	<p>Joined TMC in 1994. Worked as Head of Toyota operation – Lexus India at Toyota Kirloskar Motor India (01/01/2014 – 31/12/2017). Formerly, General Manager in Middle East & Central Asia Division. (01/06/2018 – 31/12/2021)</p>	<p>Chief Executive Office – Oceania & Middle East Region, and General Manager – Middle East & Central Asia Division (effective 1/1/2022)</p>
<p>M Rausa (Appointed 1/1/2021) Bachelor of Engineering (Mechanical)</p>	<p>Joined Toyota Australia in 1985. Formerly Senior Vice President of Purchasing in TMAPEM, General Manager in Purchasing Division, Divisional Manager of Product Development Division, Senior Divisional Manager of Purchasing & Engineering, Production Control and Quality Divisions, and Executive Director – Corporate Services (to 31/12/2017), Vice President – Product & Corporate Operations (to 31/12/2019); Vice President – Regional and Guest Operations (to 31/12/2021) in Toyota Australia</p> <p>Director – Toyota New Zealand Limited (Non-resident) to 30/06/2020, Toyota Community Foundation Australia Pty Ltd (to 30/06/2020), Hydrogen Mobility Australia Pty Ltd (to 31/08/2020) and SCT Pty Ltd Company Secretary (to 31/12/2019) Director – SCT Pty Ltd (effective 01/01/2020)</p> <p>Director/Chair – Revolution Pty Ltd. (Effective 1/4/2020)</p>	<p>Vice President – Guest, Aftersales & Corporate Operations. Finance, Procurement & Audit (effective 1/1/2022)</p> <p>Chairman – Risk & Compliance Committee</p> <p>Deputy Chief Risk Officer – Oceania Region</p> <p>Chairman – Toyota Community Foundation Australia Pty Ltd (effective 1/1/2022)</p>
<p>S Hanley (Appointed 1/1/2021)</p>	<p>Joined Toyota Australia in 1989. Held various Toyota management & executive positions within regional operations, new vehicle sales, parts & accessories, and regional management in various locations around Australia. Formally Chief Operating Officer – Lexus Australia (2013)</p> <p>Vice President – National Sales & Marketing Operations (to 31/3/2021)</p>	<p>Vice President – National Sales & Marketing Operations (1/1/2018 to 31/3/2021)</p> <p>Vice President – Sales, Marketing & Franchise Operations (effective 1/4/2021)</p>
<p>J Pappas (Appointed 1/1/2022) Bachelor of Engineering (Mechanical)</p>	<p>Joined Toyota Australia in 1997. Worked as General Manager of National Sales and National Marketing</p> <p>Formerly Area Operations General Manager (Singapore / Brunei) and Sales & Marketing Regional Fleet General Manager, TMAP-MS (2015-2016)</p> <p>Appointed Vice President & Chief Executive of Lexus Australia, and Vice President of Information & Digital Services Operations in January 2022</p> <p>Director – Toyota Finance Australia Ltd (effective March 2022)</p>	<p>Chief Executive, Lexus Australia (effective 1/1/2022)</p> <p>Vice President, Information & Digital Services Operations (effective 1/1/2022)</p>
<p>T Kanno (Appointed 1/1/2022) Bachelor of Business Accounting</p>	<p>Joined TMC in 1999. Worked in Product Planning division and Global Lexus Products. (1/4/1999 – 31/12/2008)</p> <p>Executive Coordinator at Toyota Motor Sales USA. (1/1/2009 – 31/12/2012)</p> <p>Group Manager in Product Planning at TMC. (1/1/2013 – 31/03/2016), in Lexus brand management (1/4/2016 – 30/11/2017)</p> <p>Worked as Project Manager in Secretariat Division (1/12/2017 – 31/3/2018). Worked as Project General Manager in Middle East & Central Asia Division (1/4/2018 – 31/12/2021)</p>	<p>Vice President of New Business Solutions & Product Planning Operations</p> <p>Chief Coordinating Executive (effective 1/1/2022)</p>

GRI index

Toyota Australia has reported the information cited in this GRI content index for the period 1 April 2021 to 31 March 2022 with reference to the GRI Standards.

*Asterisk indicates disclosure is partially met

Indicator	Description	Section
GRI 2 General Disclosures		
The organisation and its reporting practices		
2-1	Organisational details (including legal name, ownership, and locations of headquarters and operations)	What we do and how we create value
2-2	Entities included in the organisation's sustainability reporting	About this report
2-3	Reporting period, frequency and contact point	About this report
2-4	Restatements of information	About this report
2-5	External assurance	Assurance statement
Activities and workers		
2-6	Activities, value chain and other business relationships	What we do and how we create value Our value chain
2-7	Employees	Capable, accomplished people
2-8	Workers who are not employees	Capable, accomplished people
Governance		
2-9	Governance structure and composition	Governance
2-11	Chair of the highest governance body	Governance
2-12	Role of the highest governing body in overseeing the management of impacts	Governance
2-13	Delegation of responsibility for managing impacts	Governance
2-14	Role of the highest governance body in sustainability reporting	About this report
2-15	Conflicts of interest	Corporate policies
Strategy, policies and practices		
2-22	Statement on sustainable development strategy	President and CEO's statement
2-23	Policy commitments	Corporate policies
2-24	Embedding policy commitments	Committees Corporate policies
2-26	Mechanisms for seeking advice and raising concerns	Corporate policies
2-27	Compliance with laws and regulations	Recalls
2-28	Membership associations	External memberships and associations

Stakeholder engagement

2-29	Approach to stakeholder engagement	Our stakeholders
2-30	Collective bargaining agreements	Workforce engagement and communication

GRI 3 Material Topic Disclosures

Material topics

3-1	Process to determine material topics	Our material topics
3-2	List of material topics	Our material topics
3-3	Management of material topics	Per material topic

GRI 200 Economic Disclosures

Economic performance

201-1*	Direct economic value generated and distributed	Strong economy and thriving communities
201-2*	Financial implications and other risks and opportunities due to climate change	Lower carbon mobility
201-4	Financial assistance received from government	Advocacy and regulatory engagement

Indirect economic impacts

203-2	Significant indirect economic impacts	Indirect social and economic impacts
-------	---------------------------------------	--------------------------------------

Procurement practices

204-1	Proportion of spending on local suppliers	Suppliers
-------	---	-----------

Anti-corruption

205-2	Communication and training about anti-corruption policies and procedures	Corporate policies
205-3	Confirmed incidents of corruption and action taken	Corporate policies

Anti-competitive behaviour

206-1	Legal actions for anti-competitive behaviour, anti-trust, and monopoly practices	Corporate policies
-------	--	--------------------

GRI 300 Environmental Disclosures

Energy

302-5	Reduction in energy requirements for products and services	Hydrogen development for a decarbonised future
-------	--	--

Water and effluents

303-3*	Water withdrawal	Hydrogen development for a decarbonised future
303-4*	Water discharge	Hydrogen development for a decarbonised future
303-5*	Water consumption	Hydrogen development for a decarbonised future

Emissions		
305-1	Direct (Scope 1) GHG emissions	Energy
305-2	Energy indirect (Scope 2) GHG emissions	Energy
305-3	Other indirect (Scope 3) GHG emissions	Energy
Waste		
306-1	Waste generation and significant waste-related impacts	Manufacturing Waste reduction
306-2*	Management of significant waste-related impacts	Manufacturing Waste reduction
Environmental compliance		
307-1	Non-compliance with environmental laws and regulations	Corporate policies
Supplier environmental assessments		
308-2*	Negative environmental impacts in the supply chain and actions taken	Environmental risks
GRI 400 Social Disclosures		
Employment		
401-1*	New employee hires and employee turnover	Our ambition
401-3	Parental leave	Diversity and inclusion
Occupational health and safety		
403-1	Occupational health and safety management system	Health and safety
403-2	Hazard identification, risk assessment, and incident investigation	Health and safety
403-5	Worker training on occupational health and safety	Health and safety
403-8	Workers covered by an occupational health and safety management system	Health and safety
403-9*	Work-related injuries	Health and safety
Training and education		
404-1	Average hours of training per year per employee	Workforce skills and development
404-2	Programs for upgrading employee skills and transition assistance programs	Workforce skills and development
404-3	Percentage of employees receiving regular performance and career development reviews	Workforce skills and development
Diversity and equal opportunity		
405-1*	Diversity of governance bodies and employees	Diversity and inclusion
405-2*	Ratio of basic salary and remuneration of women to men	Diversity and inclusion
Non-discrimination		
406-1	Incidents of discrimination and corrective actions taken	Diversity and inclusion
Child labour		
408-1*	Operations and suppliers at significant risk for incidents of child labour	Modern slavery risks
Forced or compulsory labour		
409-1*	Operations and suppliers at significant risk for incidents of forced or compulsory labour	Modern slavery risks

Human rights assessment		
412-2*	Employee training on human rights policies or procedures	Modern slavery risks
Public policy		
415-1	Political contributions	Advocacy and regulatory engagement
Customer health and safety		
416-2	Incidents of non-compliance concerning the health and safety impacts of products and services	Recalls
Customer privacy		
418-1	Substantiated complaints concerning breaches of customer privacy and losses of customer data	Data privacy and security
7.5	SASB index	
Automobiles		
TR-AU-250a.2*	Number of safety-related defect complaints, percentage investigated	
Recalls		
TR-AU-250a.3	Number of vehicles recalled	Recalls
TR-AU-310a.1	Percentage of active workforce covered under collective bargaining agreements	Workforce engagement and communication
TR-AU-410a.1	Sales-weighted average passenger fleet fuel economy by region	Tailpipe emissions
TR-AU-410a.2	Number of (1) zero emissions vehicles (ZEV), (2) hybrid vehicles, and (3) plug-in hybrid vehicles sold	Lower carbon mobility
TR-AU-410a.3	Discussion on strategy for managing fleet fuel economy and emissions risks and opportunities	Reducing environmental impacts

Materiality Counts Independent Assurance Report to Toyota Australia

Scope of Work

Materiality Counts was engaged by Toyota Australia to provide independent Type 2 moderate assurance of its 2022 Sustainability Report (the Report). This assurance report was prepared for Toyota Australia and its stakeholders. The Report covers Toyota Australia's operations from 1 April 2021 to 31 March 2022, unless stated otherwise in the text. This work was performed using Materiality Counts' assurance methodology to AA1000AS v3, AccountAbility's Assurance Standard issued in August 2020. To do this, Materiality Counts interviewed Toyota Australia employees and reviewed relevant information and data collation processes, including sighting a sample of original records, interrogating spreadsheets and re-performing some calculations. The following subject matter was evaluated against criteria defined in AA1000 AccountAbility Principles (AA1000AP, 2018):

- Adherence to the AA1000AS v3 principles of materiality, inclusivity, responsiveness and impact.
- Reliability of performance information for material issues (ranked high): towards zero carbon, supply chain risk, community investment and partnerships and mobility. Material issues ranked high are included in the limited assurance scope as part of a rolling program.

- Reliability of information relating to the value creation model, part of Toyota Australia's gradual progression towards integrated reporting.

Materiality Counts' Independence

Toyota Australia was responsible for preparing the Report. Materiality Counts was responsible for expressing assurance conclusions in line with the scope of work agreed with Toyota Australia. During the reporting period, Materiality Counts did not work with Toyota Australia on other consulting engagements. Materiality Counts is an independent consultancy specialising in Sustainability and Integrated Report development and assurance, materiality determination, stakeholder engagement and strategy development.

Our Conclusion

Materiality Counts concludes that, based on the scope of work and related limitations, for the specified subject matter, Toyota Australia's 2022 Sustainability Report adheres to the AA1000AS v3 principles of inclusivity, materiality, responsiveness and impact and reports reliable performance information, based on the limitations outlined above, for 1 April 2021 to 31 March 2022. In addition, Materiality Counts has provided a management report to Toyota Australia.

Key Observations

Based on the scope of work, and without affecting our assurance conclusion, Materiality Counts makes the following observations:

Good practice:

- **Materiality principle:** Reporting of key changes in material issue rankings from 2021 to 2022 in this year's materiality report.
- **Inclusivity principle:** Extension of internal stakeholder engagement in the materiality process to 18 interviews with key personnel across the business.
- **Responsiveness principle:** Mapping each of the material topics forming the basis of this year's Report to the capitals drawn on, affected and the value created for stakeholders. Impact principle: Growth in supply chain risk reporting with plans to build on modern slavery coverage to include other environmental and social governance (ESG) risks.
- **Performance information:** Reporting a more complete Scope 3 greenhouse gas (GHG) emissions dataset by including sub-categories in areas such as marketing and IT.
- **Integrated reporting:** Progress towards integrated thinking and reporting with further development of the value creation model.

Areas for improvement:

- **Materiality principle:** Undertake external stakeholder interviews as part of the materiality process, engaging directly to understand what is most important to them.
- **Inclusivity principle:** Extend the external stakeholder sample engaged in the materiality process to include customers, community and government for a more comprehensive appreciation of their views and expectations on the material issues, allowing more effective representation of them in the Report.
- **Responsiveness principle:** Engage internal and external stakeholders in feedback on whether or not the Report covers what matters most to them. Internal stakeholder engagement on the value creation model was strong, but direct engagement with external stakeholders was lacking.
- **Impact principle:** Provide 5-year trend data, in the data tables at the end of the Report, for key metrics relating to impact for all material topics.
- **Performance information:** Validate data included in the Report using original records, spreadsheets and databases to enhance accuracy and reduce data revisions identified via assurance.

- **Integrated reporting:** Further enhance transparency as the Report progresses towards integrated reporting (IR) by reporting what didn't go well as well as what did.

Materiality Counts congratulates Toyota Australia on its continued commitment to sustainability reporting.



Jo Cain, Executive Director,
Materiality Counts, 25 October 2022,
Melbourne, Australia

Materiality Counts has prepared this statement for Toyota Australia in accordance with the standard practiced by members of the consulting profession performing this type of service at the same time. No other warranty, express or implied, is given by Materiality Counts as a result of the provision of this statement. To the extent permitted by law, this statement is provided for informational purposes only, without the right to rely, and Materiality Counts will not be liable for any reliance which may be placed on this statement by a third party. This statement may not be used by any third party without Materiality Counts' express written permission.

Materiality Counts

 **AA1000**
Licensed Report
000-185/V3-9X529

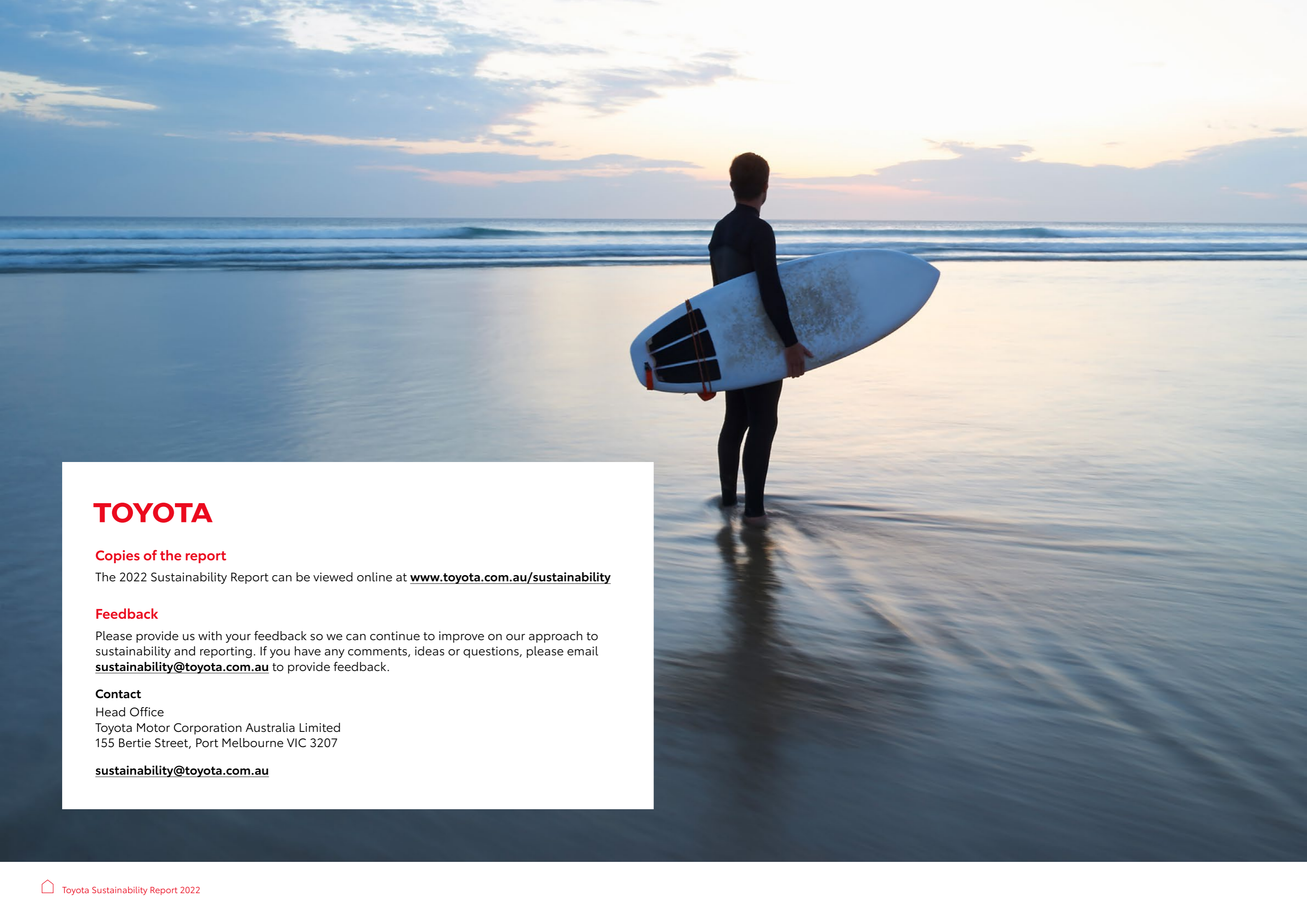

TOYOTA

Copies of the report

The 2022 Sustainability Report can be viewed online at www.toyota.com.au/sustainability

Feedback

Please provide us with your feedback so we can continue to improve on our approach to sustainability and reporting. If you have any comments, ideas or questions, please email sustainability@toyota.com.au to provide feedback.

Contact

Head Office
Toyota Motor Corporation Australia Limited
155 Bertie Street, Port Melbourne VIC 3207

sustainability@toyota.com.au